

***BOSE***

# L1 Pro16 Portable Line Array System

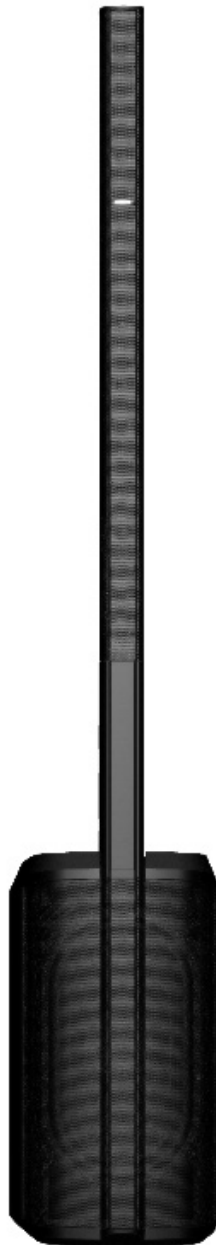

# CONTENTS

Title	Page
<b>SAFETY INFORMATION</b> .....	<b>4</b>
<b>ELECTROSTATIC DISCHARGE SENSITIVE (ESDS) DEVICE HANDLING</b> .....	<b>5</b>
<b>WARRANTY</b> .....	<b>5</b>
<b>PART LIST NOTES</b> .....	<b>5</b>
<b>PRODUCT DESCRIPTION</b> .....	<b>6-8</b>
<b>PACKAGING PART LIST</b> .....	<b>9</b>
Figure 1. Packaging Exploded View .....	<b>9</b>
<b>MAIN ASSEMBLY LIST, L1 Pro16 Power Stand</b> .....	<b>10-12</b>
Figure 2. L1 Pro16 Power Stand Exploded View .....	<b>12</b>
<b>MAIN ASSEMBLY LIST, L1 Pro16 IO Panel Assy</b> .....	<b>13-15</b>
Figure 3. L1 Pro16 IO Panel Assy Exploded View .....	<b>16</b>
<b>MAIN ASSEMBLY LIST, L1 Pro16 Array Speaker</b> .....	<b>17</b>
Figure 4. L1 Pro16 Array Speaker Exploded View .....	<b>18</b>
<b>MAIN ASSEMBLY LIST, L1 Pro16 Extension</b> .....	<b>19</b>
Figure 5. L1 Pro16 Extension Exploded View .....	<b>19</b>
<b>MAIN-I/O PCB PART LIST</b> .....	<b>20-28</b>
<b>POWER-AMP PCB PART LIST</b> .....	<b>29-35</b>
<b>VOLUME PCB PART LIST</b> .....	<b>36</b>
<b>DISASSEMBLY PROCEDURE</b> .....	<b>37-43</b>
Figure 6. PC Sheets Location .....	<b>37</b>
Figure 7. PC Sheets Removal .....	<b>37</b>
Figure 8. Enclosure Bottom Screws Removal.....	<b>37</b>
Figure 9. Enclosure Bottom Removal .....	<b>38</b>
Figure 10. Grille Removal .....	<b>38</b>
Figure 11. I/O Panel Assy Screws Removal .....	<b>38</b>
Figure 12. Incline the Power Stand .....	<b>39</b>
Figure 13. Main-IO Board & Power-Amp Board Cables .....	<b>39</b>
Figure 14. Antenna Board Screws Removal .....	<b>39</b>
Figure 15. Power-Amp Board Screws Removal.....	<b>40</b>
Figure 16. Heat Sink Glue .....	<b>40</b>
Figure 17. Shield Cover Screws Removal 1.....	<b>40</b>
Figure 18. Shield Cover Screws Removal 2.....	<b>40</b>
Figure 19. White Glue Removal.....	<b>41</b>
Figure 20. Fire Box & Main-IO Board Screws Removal.....	<b>41</b>
Figure 21. 4 Jacks and Jack Socket Nut Removal.....	<b>41</b>
Figure 22. Volume Board Screws Removal.....	<b>42</b>
Figure 23. Woofer Screws Removal.....	<b>42</b>
Figure 24. Press the White Fastener.....	<b>42</b>
Figure 25. Both Ends of Endcaps Screws Removal.....	<b>42</b>
Figure 26. Lower Endcap Removal.....	<b>43</b>
Figure 27. Array Grille Removal.....	<b>43</b>
Figure 28. Gasket Material Locations.....	<b>43</b>
Figure 29. Driver Screws & Cable Removal.....	<b>43</b>

# CONTENTS

Title	Page
TEST PROCEDURE.....	44-48
HI-POT TEST.....	49
SOFRWARE UPDATE.....	50-51
SERVICE MANUAL REVISION HISTORY.....	52

# SAFETY INFORMATION

1. Parts that have special safety characteristics are identified by the  symbol on schematics or by special notes on the parts list. Use only replacement parts that have critical characteristics recommended by the manufacturer.
2. Make leakage current or resistance measurements to determine that exposed parts are acceptably insulated from the supply circuit before returning the unit to the customer.

Use the following checks to perform these measurements:

**A. Leakage Current Hot Check** - With the unit completely reassembled, plug the AC line cord directly into a 264V (line-neutral), 60Hz power source. (Do not use an isolation transformer during this test.)

Use a leakage current tester or a metering system that complies with American National Standards Institute (ANSI) UL 101 "Leakage Current for Appliances" and Underwriters Laboratories (UL) 60065/ IEC 60065 Clause 9.1.1.

With the unit Standby switch either in the ON position or OFF position, measure from a known earth ground (metal waterpipe, conduit, etc.) to all exposed metal parts of the unit (antennas, handle bracket, metal cabinet, screwheads, metallic overlays, control shafts, etc.), especially any exposed metal parts that offer an electrical return path to the chassis.

Any current measured must not exceed 3.5 mA (or MIU). Reverse the unit power cord plug in the outlet and repeat test.

ANY MEASUREMENTS NOT WITHIN THE LIMITS SPECIFIED HEREIN INDICATE A POTENTIAL SHOCK HAZARD THAT MUST BE ELIMINATED BEFORE RETURNING THE UNIT TO THE CUSTOMER.

**B. Insulation Resistance Test Cold Check** - (1) Unplug the power supply and connect a jumper wire between line and neutral blades the plug.

(2) Measure the resistance with an ohmmeter between the jumpered AC plug and each exposed metallic cabinet part on the unit. The resistance measured to the metal panel should be between 2 and infinite MOhms. Also, the resistance measured to exposed input/output connectors should be between 4 and infinite MOhms.

If it is not within the limits specified, there is the possibility of a shock hazard, and the unit must be repaired and rechecked before it is returned to the customer.

**CAUTION:** The Bose L1 Pro16 Portable Line Array System contains no user-serviceable parts. To prevent warranty infractions, refer servicing to warranty service stations or factory service.

## PROPRIETARY INFORMATION

THIS DOCUMENT CONTAINS PROPRIETARY INFORMATION OF BOSE CORPORATION WHICH IS BEING FURNISHED ONLY FOR THE PURPOSE OF SERVICING THE IDENTIFIED BOSE PRODUCT BY AN AUTHORIZED BOSE SERVICE CENTER, AND SHALL NOT BE REPRODUCED OR USED FOR ANY OTHER PURPOSE.

# Electrostatic Discharge Sensitive (ESDS) Device Handling

This unit contains ESDS devices. We recommend the following precautions when repairing, replacing or transporting ESDS devices:

- Perform work at an electrically grounded work station.
- Wear wrist straps that connect to the station or heel straps that connect to conductive floor mats.
- Avoid touching the leads or contacts of ESDS devices or PC boards even if properly grounded. Handle boards by the edges only.
- Transport or store ESDS devices in ESD protective bags, bins, or totes. Do not insert unprotected devices into materials such as plastic, polystyrene foam, clear plastic bags, bubble wrap or plastic trays.

## WARRANTY

The Bose L1 Pro16 Portable Line Array System is covered by a limited 5-year transferable warranty. Units that fail within 90 days of sale should be replaced.

## PART LIST NOTES

1. The individual parts located on the PCBs are listed in the Electrical Part List.
2. This part is referenced for informational purposes only. It is not stocked as a repair part. Refer to the next higher assembly for a replacement part.
3.  This part is critical for safety purposes. Failure to use a substitute replacement with the same safety characteristics as the recommended replacement part might create shock, fire and/or other hazards.

# PRODUCT DESCRIPTION

L1 Pro16 Portable Line Array System is the most compact, most portable, play-anywhere system. The system is ideal for Singer-Songwriter with 16 Twiddlers and one subwoofer.

Before connecting the system to a power source, assemble the system using the array extension and mid-high array.

1. Insert the array extension into the subwoofer power stand.
2. Insert the mid-high array into the array extension.

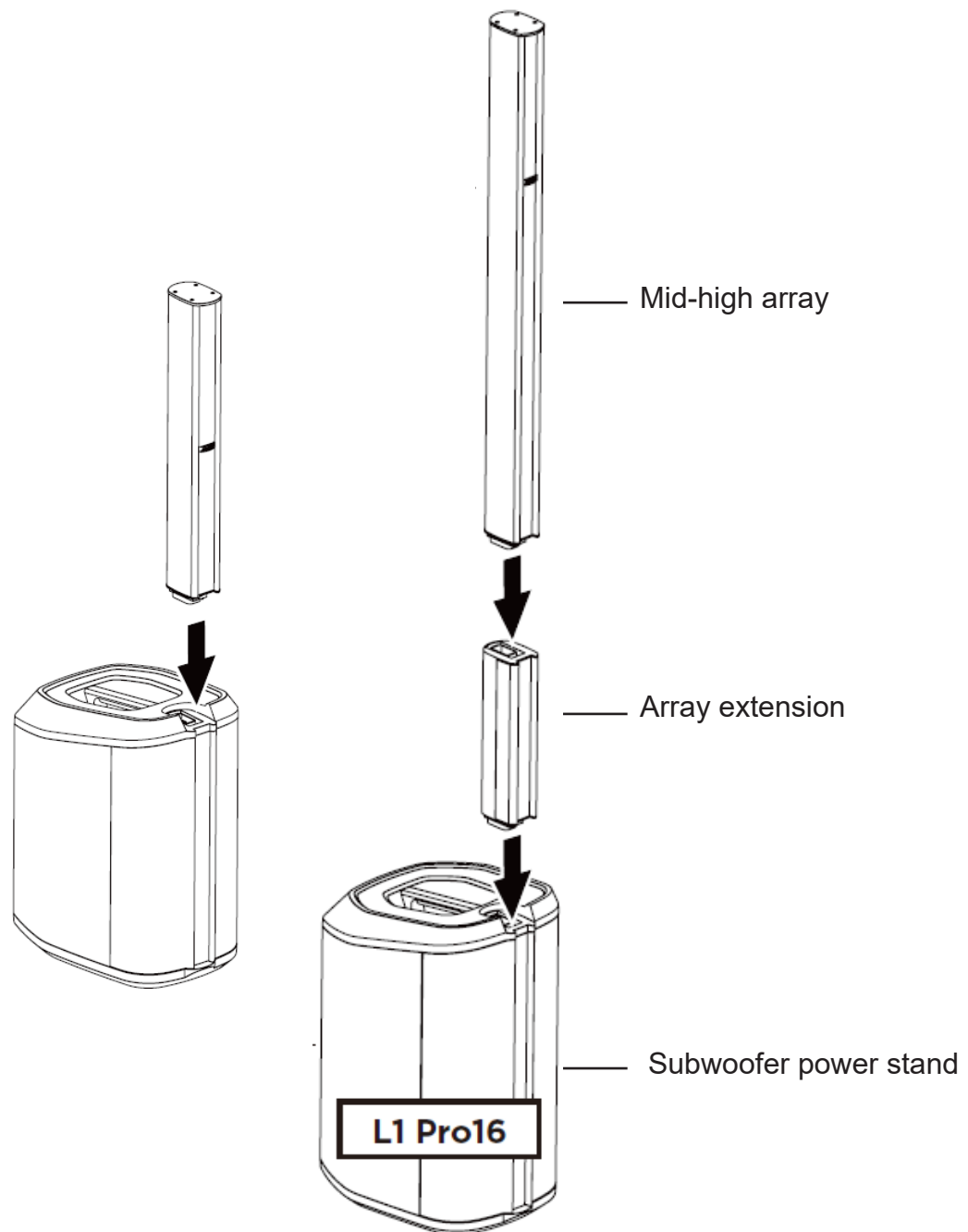

The L1 Pro16 can be assembled without using the array extension; the mid-high array can be connected directly to the subwoofer power stand. This configuration is most useful when on an elevated stage to be sure the mid-high array is at ear level.

# PRODUCT DESCRIPTION

## Connections and Controls

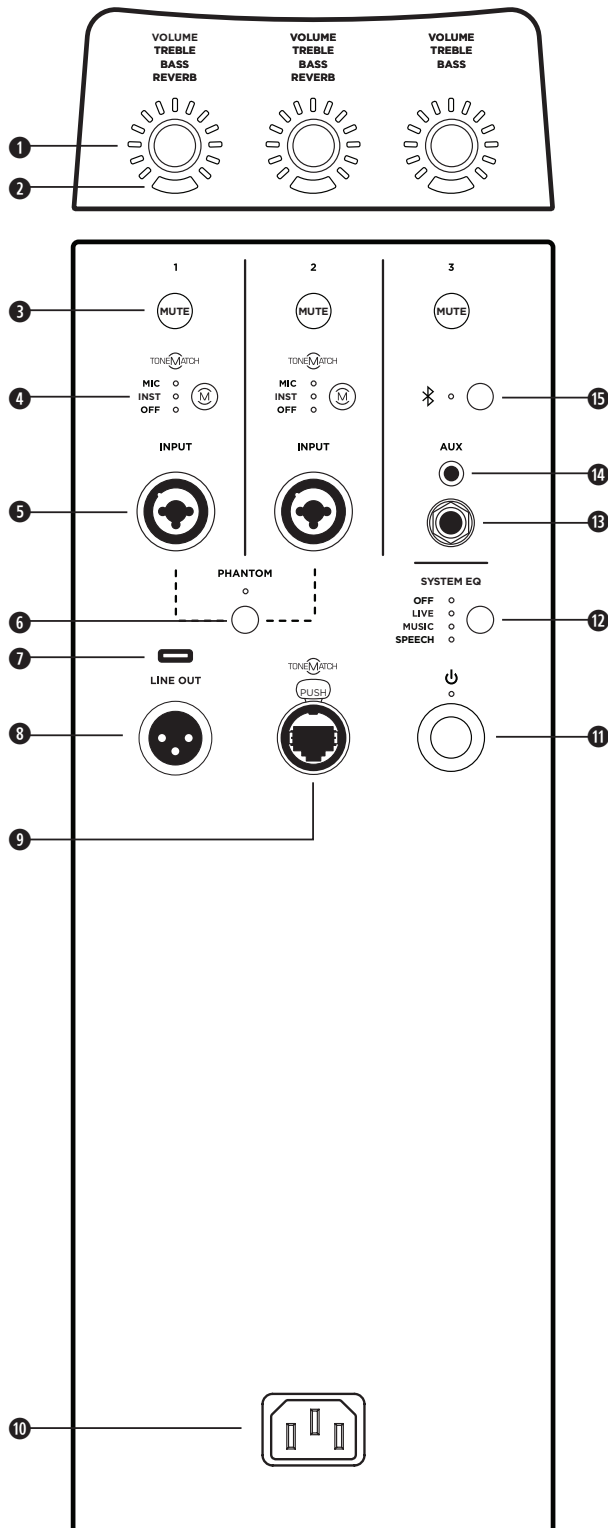

- 1 **Channel Parameter Control:** Adjust the level of volume, treble, bass, or reverb for your desired channel. Press the control to switch between parameters; rotate the control to adjust the level of your selected parameter.
  - 2 **Signal/Clip Indicator:** The LED will illuminate green when a signal is present and will illuminate red when the signal is clipping or the system is entering limiting. Reduce the channel or signal volume to prevent signal clipping or limiting.
  - 3 **Channel Mute:** Mute the output of an individual channel. Press the button to mute the channel. While muted, the button will illuminate white.
  - 4 **Channel ToneMatch Button:** Select the ToneMatch preset for an individual channel. Use **MIC** for microphones and use **INST** for acoustic guitar. The corresponding LED will illuminate white while selected.
  - 5 **Channel Input:** Analog input for connecting microphone (XLR), instrument (TS unbalanced), or line level (TRS balanced) cables.
  - 6 **Phantom Power:** Press the button to apply 48-volt power to channels 1 and 2. The LED will illuminate white while phantom power is applied.
  - 7 **USB Port:** USB-C connector for Bose service use. **Note:** This port is not compatible with Thunderbolt 3 cables.
  - 8 **XLR Line Output:** Use an XLR cable to connect the line-level output to a Sub1/Sub2 or another bass module.
  - 9 **ToneMatch Port:** Connect your L1 Pro to a T4S or T8S ToneMatch mixer via a ToneMatch cable.
- CAUTION:** Do not connect to a computer or phone network.
- 10 **Power Input:** IEC power cord connection.
  - 11 **Standby Button:** Press the button to power on the L1 Pro. The LED will illuminate white while the system is on.
  - 12 **System EQ:** Press the button to scroll through and select a master EQ suitable for the use case. The corresponding LED will illuminate white while selected.
  - 13 **TRS Line Input:** Use a 6.4-millimeter (¼-inch) TRS cable to connect line-level audio sources.
  - 14 **Aux Line Input:** Use a 3.5-millimeter (⅛-inch) TRS cable to connect line-level audio sources.
  - 15 **Bluetooth® Pair Button:** Set up pairing with Bluetooth capable devices. The LED will flash blue while the L1 Pro is discoverable and illuminate solid white when a device is paired for streaming.

# PRODUCT DESCRIPTION

## Connecting Sources

### Channel 1 & 2 Controls

Channel 1 and 2 are for use with microphones, guitars, keyboards, or other instruments. Channel 1 and 2 will automatically detect a source input level to adjust volume taper and gain stage.

1. Connect your sound source to the **Channel Input** with the appropriate cable.
2. Apply a ToneMatch preset—to optimize the sound of your microphone or instrument—by pressing the **Channel ToneMatch Button** until the LED for your chosen preset is illuminated. Use **MIC** for microphones and use **INST** for acoustic guitars and other instruments. Use **OFF** if you do not want to apply a preset.

**Note:** Use the L1 Mix app to choose custom presets from the ToneMatch library. The corresponding LED will illuminate green when a custom preset is selected.

3. Press the **Channel Parameter Control** to choose a parameter to modify. The parameter name will illuminate white while it is selected.
4. Rotate the **Channel Parameter Control** to adjust the level of the selected parameter. The parameter LED will indicate the level of the selected parameter.

**Note:** While **Reverb** is selected, press and hold the control for two seconds to mute the reverb. While reverb is muted, **Reverb** will flash white. To unmute reverb, press and hold for two seconds while **Reverb** is selected. Reverb mute will reset when the system is powered off.

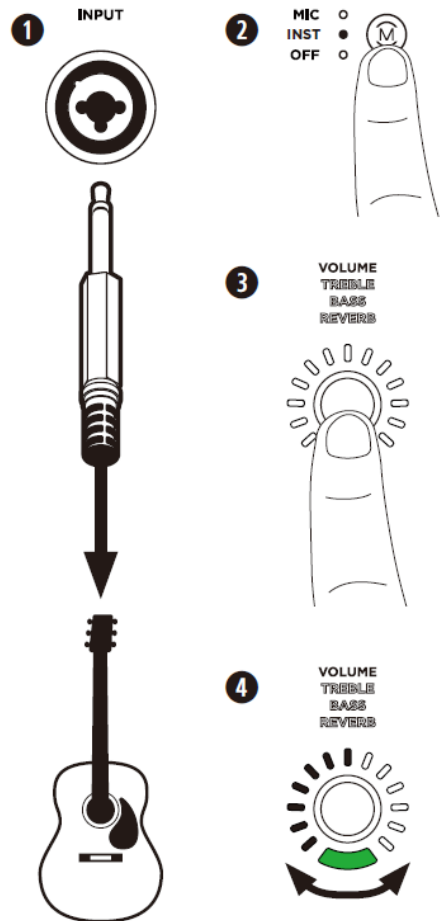

### Channel 3 Controls

Channel 3 is for use with *Bluetooth*® enabled devices and line-level audio inputs.

#### Bluetooth Pairing

The following steps describe how to manually connect a *Bluetooth* enabled device to stream audio.

You can use the L1 Mix app to access additional device control. For more information on the L1 Mix app, see **L1 Mix App Control** below.

1. Turn on the *Bluetooth* feature on your mobile device.
2. Press and hold the **Bluetooth Pair Button** for two seconds. When ready to pair, the LED will flash blue.



3. Your L1 Pro will be visible in your device list on your mobile device. Select your L1 Pro from the device list. When the device pairs successfully, the LED will illuminate solid white.

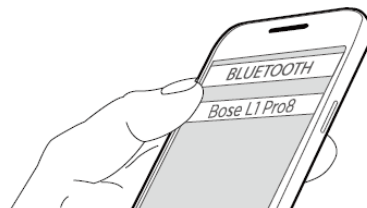



# Packaging Part List

L1 Pro16 (includes Array) (see Figure 1)

Item Number	Description	Bose Part Number	Vendor Part Number	Notes
1	CARTON	857754-0010	T302001480000	
2	EXTENSION ASSY	833350-0110	T910000080320	
3	CARRY BAG, BLACK	856994-0110	T310000077000	
4	MANUAL BAG	865047-0010	-	
5	FOAM EPE TOP WHITE 25KG/M3	857744-0010	-	
6	FOAM EPE BOTTOM	857752-0010	-	
7	CARDBOARD SUPPORT	857746-0010	-	
8	SAFETY SHEET	857139-0010	-	
9	QSG	857138-0010	-	
10	SHEET,USER SOFTWARE UPDATE GUIDE	865083-0010	-	
11	CABLE, LINE CORD, IEC C13, NA	350745-0010	T640100016600	3 
	CABLE, LINE CORD, EC C13, EU	350747-0010	T640100015400	
	CABLE, LINE CORD, IEC C13, JP	350749-0020	T640100015500	
	CABLE, LINE CORD, IEC C13, UK	350748-0010	T640100015200	
	CABLE, LINE CORD, IEC C13, AU	350746-0010	T640100021100	

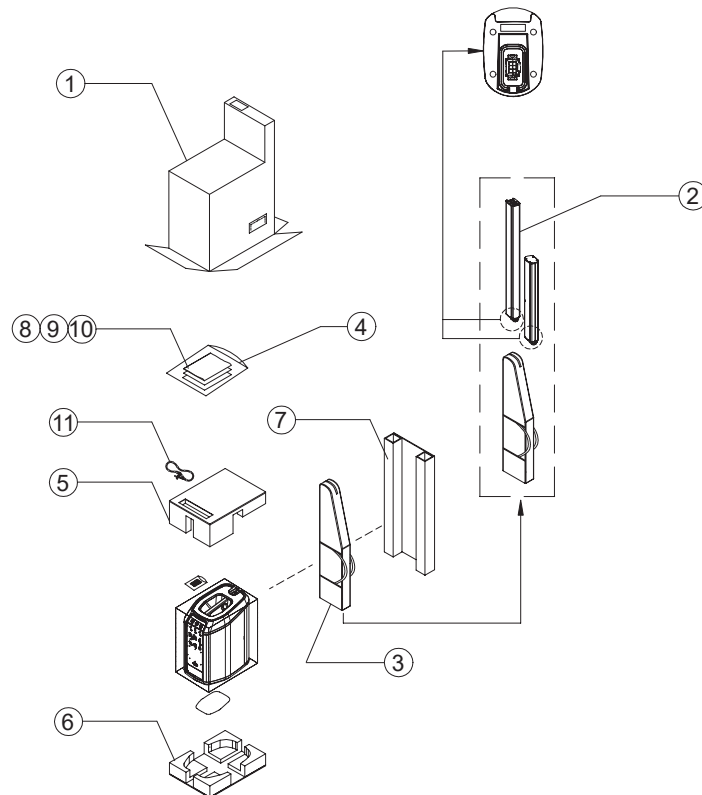

Figure 1. L1 Pro16 Packaging Exploded View

# Main Part List

L1 Pro16 Power Stand (see Figure 2)

Item Number	Description	Material Number	Vendor Part Number	Qty/Note
1	NON WOVEN SHEET FOR GRILLE 1	-	T182900003140	
2	NON WOVEN SHEET FOR GRILLE LONG	-	T182900003150	
3	LINT SHEET FOR GRILLE 1	-	T182900003130	
4	POWER STAND GRILLE	861930-011S	T130207800100	
5	RUBBER BUMPER	-	T180200016480	
6	WF CABLE 4P 3.96 VH-4Y-32 K	-	T641700186500	
7	SCREW T4.0XL20 3.18P BZN+CED COATING	-	T15340201F600	
8	RUBBER SHEET_GRILLE TOP MID	-	T180200017570	
9	RUBBER SHEET_GRILLE TOP LR	-	T180200017560	
10	SCREW T4.0XL20 2.3P ZINC+CED COAT K	-	T15340201F631	
11	GASKET FOR WOODEN BRACKET TOP	-	T180500031330	
12	CABINET LEFT	-	T100425300100	
13	POWER WADDING	-	T182700002510	
14	BRACKET	-	T130207500100	
15	FOAM STRIP TOP	-	T180200015790	
16	SCREW T4.0XL25 3.18P BZN+CED COATING	-	T15340251F600	
17	SCREW, T3.5xL14	-	T15335142F610	
18	COVER SEAL ARRAY CONNECTOR	-	T100424300100	
19	SOLDER LUG OD8.0*ID4.1*L56 G	-	T690300045600	
20	GASKET FOR ENDCAP SEAL COVER	-	T180500031060	
21	TW1+EQ CABLE 6PIN MOLEX 42474-6Y-VH-04 K	-	T61700176200	
22	VOL CONNECT CABLE 10PIN ZH-11Y-ZH-03 K	-	T641700180100	
23	SCREW, M8xL30	-	T15180302F410	
24	FLAT WASHER M8	-	T181200000590	
25	SPRING WASHER, M8	-	T181200000740	
26	END CAP TOP	-	T100425600100	
27	GASKET FOR HANDLE A	-	T180500032720	
28	HANDLE	-	T100403900100	
29	GASKET FOR HANDLE B	-	T180500032710	
30	NUT (FOR HANDLE)	-	T181000000660	

# Main Part List

L1 Pro16 Power Stand (see Figure 2)

Item Number	Description	Material Number	Vendor Part Number	Qty/Note
31	INLAY VOLUME SHEET	-	T180700009350	
32	VOLUME KNOB	841657-0110	T100403800100	
33	RUBBER RING	-	T180200016500	
34	GASKET VOLUME PCB 1	-	T180500031000	
35	BRACKET VOLUME PCB	-	T100402800100	
36	GASKET VOLUME PCB 2	-	T180500033870	
37	PCB SUBASSY, VOLUME, SVCE	861359-001S	T910000074760	
38	VOL CONNECT CABLE 10PIN ZH-10Y-ZH-08 K	-	T641700180000	
39	GASKET_ANTENNA BRACKET	-	T180500031200	
40	ANTENNA BRACKET	-	T100424500100	
41	SCREW T3xL16_FLAT	-	T151301630610	
42	AMP_MAIN PCBA ASSY	-	T910000075290	
43	SPRING WASHER, M4	-	-	
44	SCREW, T4xL16	-	T15340161F610	
45	LINT SHEET FOR METAL BRACKET	-	T180000009230	
46	FOAM STRIP FRONT	-	T180200015780	
47	NON WOVEN SHEET_BLACK_ADHESIVE	-	T182900003120	
48	CABINET RIGHT	-	T100425400100	
49	GASKET FOR WOODEN BRACKET	-	T180500031080	
50	WOOD BRACKET 2	-	T180400001000	
51	WOOD BRACKET	-	T180400001010	
52	CURVED PORT	-	T100425500100	
53	GASKET_CABINET_BOTTOM	-	T180500031350	
54	WADDING PORT 20KGM3	-	T182700002670	
55	FOAM STRIP BOTTOM	-	T180200015800	
56	GASKET_END CAP BOTTOM & CABINET	-	T180500031360	
57	GASKET_PORT RIGHT	-	T180500031300	
58	GASKET_END CAP BOTTOM & CABINET	-	T180500031340	
59	END CAP BOTTOM	-	T100425700100	
60	BOTTOM SHEET RIGHT	857290-0120	T180700009420	
61	BOTTOM SHEET_PC	861137-0110	T180700009950	
62	PRODUCT LABEL	857291-0110	T180700009570	3 
63	FEET RIGHT	-	T180200016540	

# Main Part List

L1 Pro16 Power Stand (see Figure 2)

Item Number	Description	Material Number	Vendor Part Number	Qty/Note
64	BOTTOM SHEET LEFT	857290-0110	T180700009410	
65	FEET LEFT	-	T180200016530	
66	SCREW T4.0XL10 1.41P BZN+CED COATING	-	T15340101F611	
67	GASKET PORT SUPPORT	-	T180500031040	
68	GASKET_PORT CENTER	-	T180500031320	
69	GASKET_PORT LEFT	-	T180500031310	
70	WOOFER, RT LARGE	830125-0110	T911600011320	3 

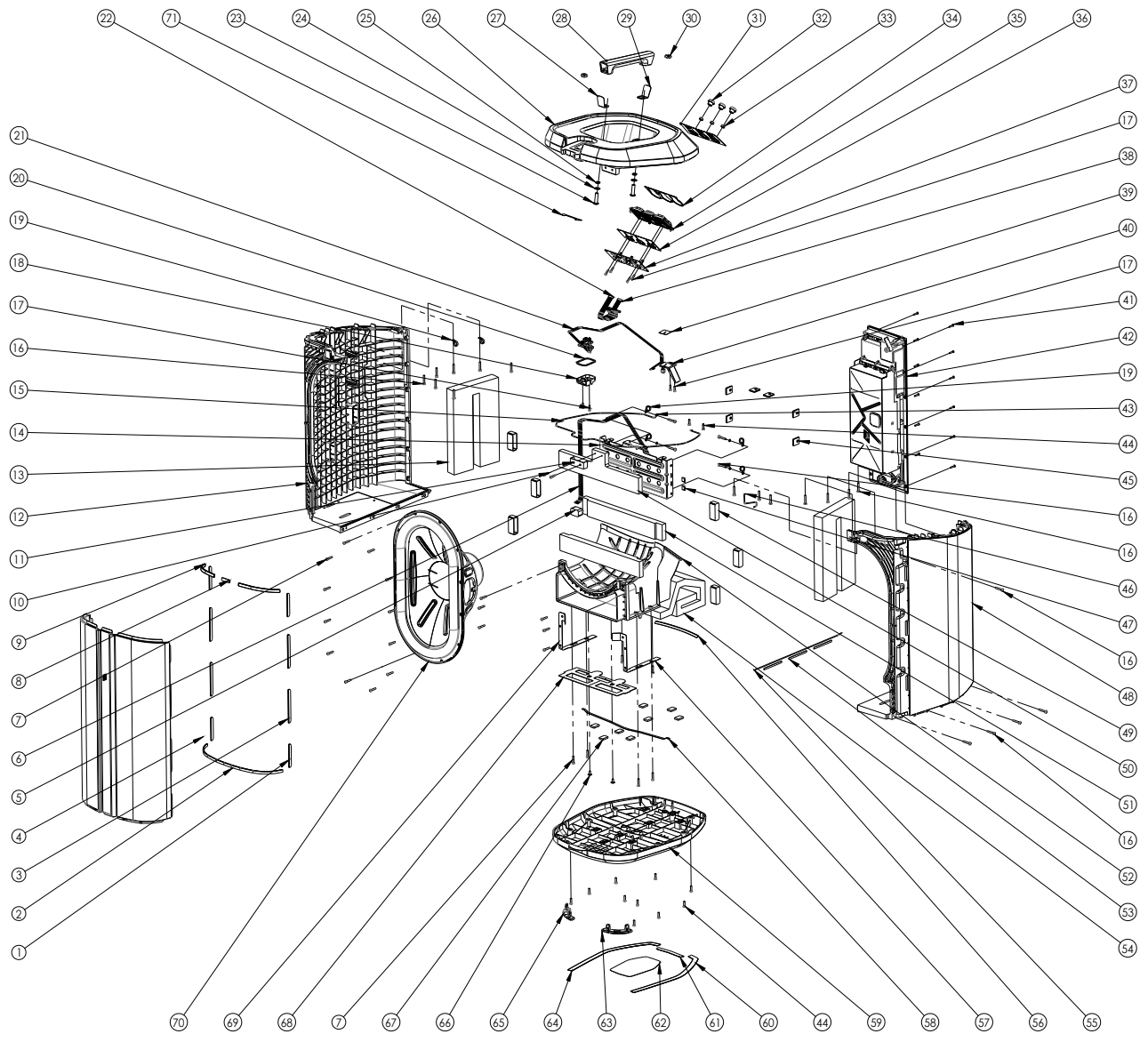

Figure 2. L1 Pro16 Power Stand Exploded View

# Main Part List

L1 Pro16 I/O Panel Assy (see Figure 3)

Item Number	Description	Material Number	Vendor Part Number	Qty/Note
1	SCREW M3xL10_FLAT	-	T151301030610-02	
2	SCREW, T3xL12(FOR JACK)	-	T153301210630	
3	6.35MM STEREO JACK NJ6FD-VK	-	T710200019500	
4	NON WOVEN SHEET FOR BUT-TONS	-	T182900003040	
5	NON WOVEN SHEET_BLACK_ADHESIVE DS11 L46XW29.8XT0.3 K	-	T182900003180	
6	PE FOAM_BLACK_ADHSIVE DS11 OD13XID8.5XT1.0	-	T180500032780	
7	PE FOAM_BLACK_ADHSIVE DS11 OD16XID11.5XT1.0 K	-	T180500032760	
8	EVA_38 DEGREE_BLACK_ADHE-SIVE_DS11	-	T180500030670	
9	BUTTON MUTE	-	T100403300200	
10	BUTTON PHANTOM	-	T100403400100	
11	BUTTON SELECTION PC+ABS 94V0 BLACK K	-	T100402900100	
12	NON WOVEN SHEET FOR FIRE BOX 1	-	T182900003060	
13	NON WOVEN SHEET FOR FIRE BOX 2	-	T182900003070	
14	POLARITY LIGHT GUDIE	-	T100402300100	
15	EVA_38 DEGREE_BLACK_ADHSIVE DS11 L44XW24XT0.5 K	-	T180500032750	
16	SCREW, M3XL9	-	T15130091C610	
17	HOT MELT GLUE #1-286	-	T980200000360-02	
18	GREEN GLUE HAOZHENG: HD-200G	-	T980200000170	
19	GASKET FOR PCB CONNECTOR 2	-	T180500031150	
20	OD9XT4MM	-	T180500032640	
21	GASKET FOR FIRE BOX 2	843000-0120	T180500031100	
22	ASSY, PCB, ANTENNA AND CABLE	796036-001S	T690800019100	
23	GASKET FOR FIRE BOX 3	843000-0110	T180500031120	
24	THERMAL PAD 4	-	T181700001690	
25	SPRING WASER, M3	-	T181200000270	
26	HEATSINK EXTRUSION	-	T130217100100	
27	SPACER 20.1 PA66-ROW 94V0 NATUR	-	T100462000100	
28	SPACER 24.4 PA66-ROW 94V0 NATUR	-	T100461700100	

# Main Part List

L1 Pro16 I/O Panel Assy (see Figure 3)

Item Number	Description	Material Number	Vendor Part Number	Qty/Note
29	SCREW, T3xL10	-	T15330101F611	
30	HEATSINK CHIPSET POWER	-	T130203600200	
31	GEL 30	-	T980200001430	
32	THERMAL PAD 3	-	T181700001680	
33	POWER-AMP BOARD	863628-001S	T910000074770	
34	THERMAL PAD_CONDUCTIVE SILICONE_H50 K	-	T181700001730	
35	HEATSINK STANDBY IC	-	T130211300100	
36	HEATSINK AMP CHIPSET POWER	-	T130203500110	
37	HEATSINK CHIPSET POWER BACK	-	T130203700300	
38	SCREW, M3XL9	-	T15130091C610	
39	SHIELD COVER	-	T130208000100	
40	SCREW (FOR SHIELD COVER)	-	T153300612631	
41	SCREW M3XL14 0.5P BLUE ZINC+HT K	-	T15130141F611	
42	SPONGE_YU356A FOAM_ADHSIVE 3212 K	-	T180500032730	
43	GASKET FOR SHIELD COVER 3	-	T180500030690	
44	SCREW, T3xL20	-	T15330201F610	
45	SILICONE GLUE SLD-8854	-	T980200000210	
46	HEATSINK RECTIFIER BRIDGE POWER PCBA	-	T130203800100	
47	U CLIP	-	T180200016470	
48	SCREW, T3xL12	-	T15330122F610	
49	THERMAL PAD POWER CHIPSET	-	T181700001700	
50	EVA FOAM_38 DEGREE_BLACK_ADHSIVE DS11	-	T180500032670	
51	SMPS CONNECT CABLE P3.96 3PIN VH-3Y88 K	-	T641700170300	
52	GASKET_IO PANEL_ENCLOSURE-L	857362-0010	T180500031380	
53	GASKET_IO PANEL_ENCLOSURE-R	857362-0020	T180500031370	
54	GASKET FOR PANEL	843001-0110	T180500031130	
55	FIRE BOX	-	T100402700100	
56	GASKET FOR PCB CONNECTOR1	-	T180500031140	
57	ASSY, PCBA, MAIN-IO, PROG, SVCE	865429-001S	T910000074740	
58	GLUE K-704NB	-	T980200000680	

# Main Part List

L1 Pro16 I/O Panel Assy (see Figure 3)

Item Number	Description	Material Number	Vendor Part Number	Qty/Note
59	EVA_38 DEGREE_BLACK_ADHSIVE DS11 L24XW22XT0.5 K	-	T180500032740	
60	EVA 38°+PET L32.6XW28.1XT0.5MM K	-	T180500032680	
61	POWER LIGHT GUIDE	-	T100402400100	
62	NUT, M4	-	T181000001240	
63	EQ LIGHT GUIDE	-	T100402200100	
64	1P YELLOWGREEN 16AWG UL1015 100MM X-P K	-	T641700184000	
65	GASKET FOR FIRE BOX 1	-	T180500031090	
66	TUBE PVC 30	-	T690200008700	
67	BUTTON SELECTION 1	-	T100403500100	
68	POWER BUTTON	-	T100401900100	
69	HOT MELT GLUE XH150	-	T980200000440	
70	PE FOAM_BLACK_ADHSIVE DS11 OD19XID13XT1.0 K	-	T180500032770	
71	POWER BUTTON RING	-	T100402100100	
72	NUT M3	-	T181000000520	
73	PLUG 250VA 10A NA JINJIA K	-	T691200007600	3 
74	IO PANEL	-	T130202500100	
NA	GAP FILLER, THERMAL, ONE PART, 55CC	749859-0020	-	

# I/O Panel Assy Exploded View

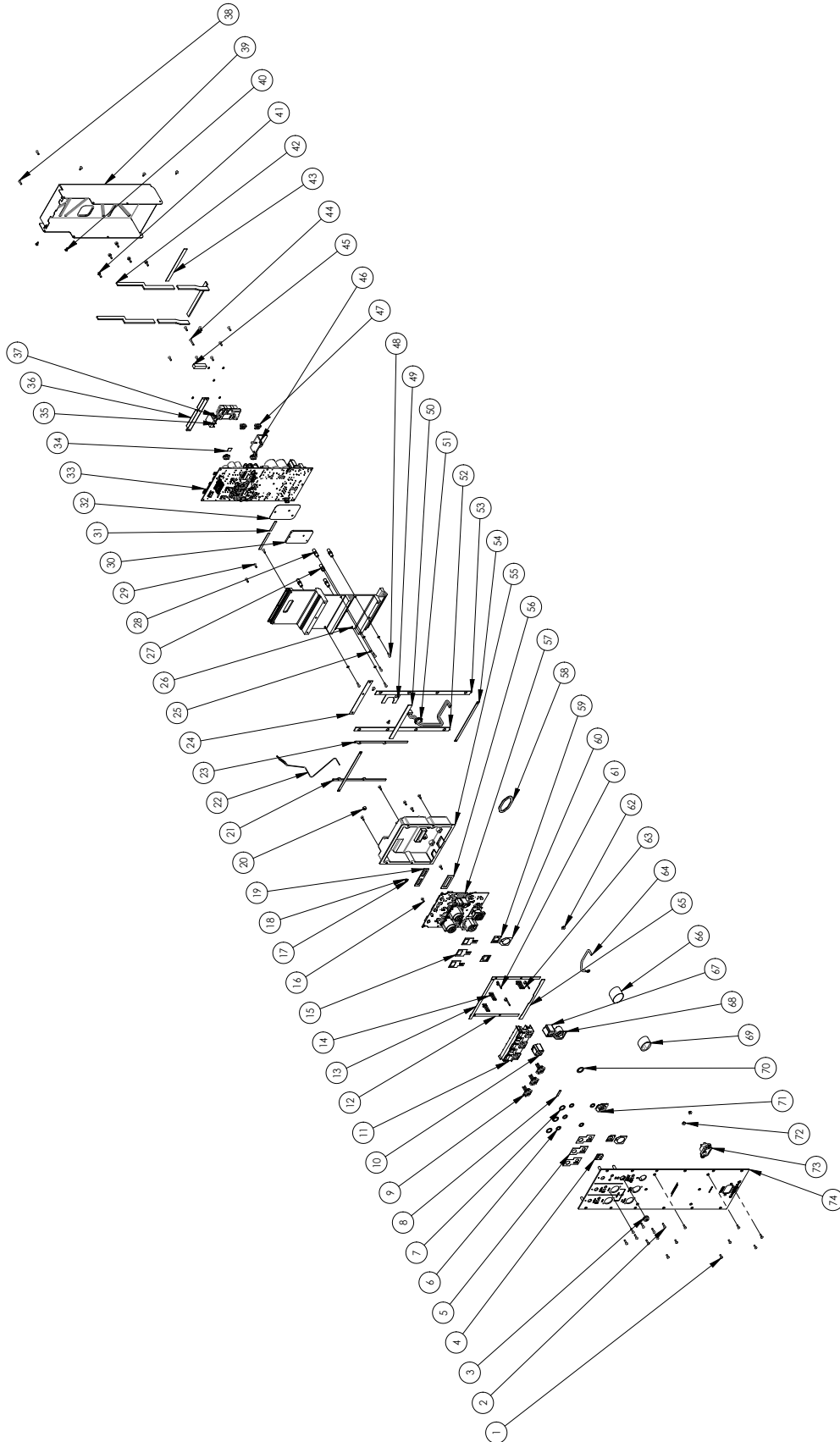



Figure 3. L1 Pro16 I/O Panel Assy Exploded View



# Main Part List

L1 Pro16 Array Speaker (see Figure 4)

Item Number	Description	Material Number	Vendor Part Number	Qty/Note
1	SCREW T3xL12_FLAT	-	T153301230610-02	
2	END CAP ARRAY UPPER	826315-0110	T100424700100	
3	GASKET FOR TOP ENDCAP	-	T180500031070	
4	NON WOVEN ARRAY GRILLE	-	T182900003220	
5	PUSH ON WASHER	-	T181200001410	
6	GRILLE ARRY, SVCE (INCLUDES BOSE LOGO)	863633-011S	T130198500100	
7	ARRAY LOGO NAMEPLATE	-	T100424600100	
8	DOUBLE SIDE TAPE FR ARRAY LOGO	-	T180000008760	
9	BAFFLE ARRAY COMMON	-	T100426200100	
10	TW CONNECT SINGLE CABLE 120MM X-P-1967 K	-	T641700168700	
11	ARRAY CABLE 6PIN SMP396-2Y-01 K	-	T641700170800	
12	SCREW, T3xL10	-	T15330101F611	
13	NUT SPRING LOCK M3X0.5PXH4MM	-	T181000001460	
14	NON WOVEN SHEET FOR GRILLE 1	-	T182900003140	
15	SCREW, M3xL12	-	T151301210610	
16	6PIN MOLEX 42475-6Y-VH-02 K	-	T641700171400	
17	DRIVER, 2 IN	812886-0010	T911600010920	3 
18	ARRAY LABEL	-	T911700056740	
19	END CAP ARRAY LOWER	833733-0110	T100424400100	
20	BAFFLE ARRAY LOWER	-	T100425800100	
21	ENCLOSURE ARRAY LOWER	-	T100425900100	
22	FOAM STRIP FOR ARRAY 1	-	T180200015730	
23	FOAM FOR CALBE PLUG	-	T180500028000	
24	GASKET FOR ARRAY ENCLOSURE	-	T180500031050	
25	SCREW, T3xL15	-	T15330151F610	
26	BRACKET ARRAY COMMON	-	T13020810010A	
27	ENCLOSURE CU ABS 94HB BLACK K	-	T100426300100	
28	FOAM STRIP FOR ARRAY	-	T180200015810	
29	ARRAY WADDING	-	T182700002500	
30	HOT MELT GLUE XH150	-	T980200000440	
31	NON WOVEN SHEET	-	T182900003370	

# Array Speaker Exploded View

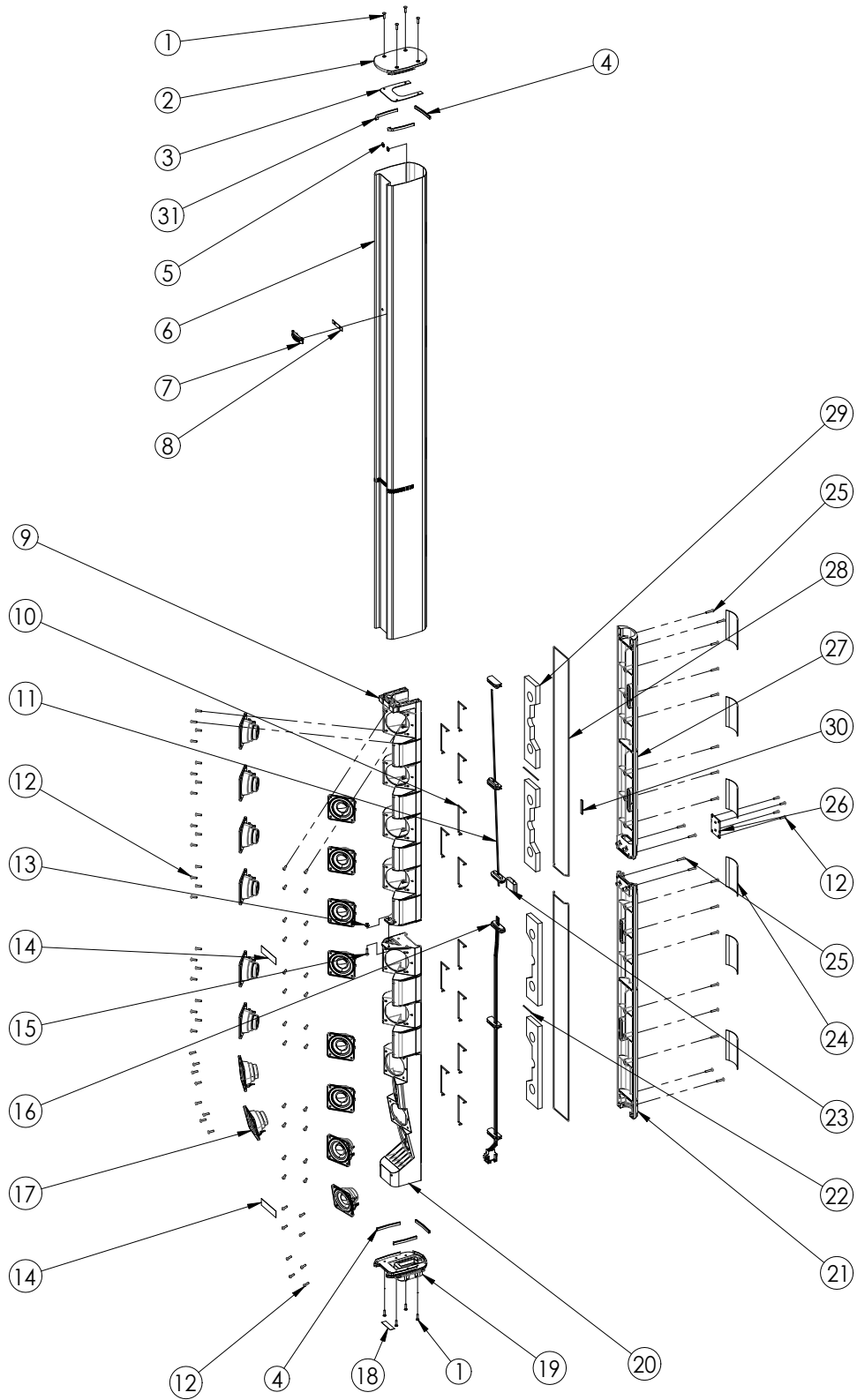

Figure 4. L1 Pro16 Array Speaker

# Main Part List

L1 Pro16 Extension (see Figure 5)

Item Number	Description	Bose Part Number	Vendor Part Number	Notes
1	SCREW, T3XL12	-	T153301230610-02	
2	EXTENSION, REAR	-	T100426100100	
3	CABLE, EXTEND, 6PIN,MOLEX	-	T641700170900V	
4	EXTENSION, FRONT	-	T100426000100	
5	NON WOVEN, SHEET_BLACK_ADHESIVE, DS1	-	T182900003170	
6	ARRAY LABEL	-	T911700056740	

**Note:** The array extension is not repairable. The above parts are listed for reference only.

Bose part number is 833350-0110 (EXTENSION ASSY) as listed in the packaging parts list.

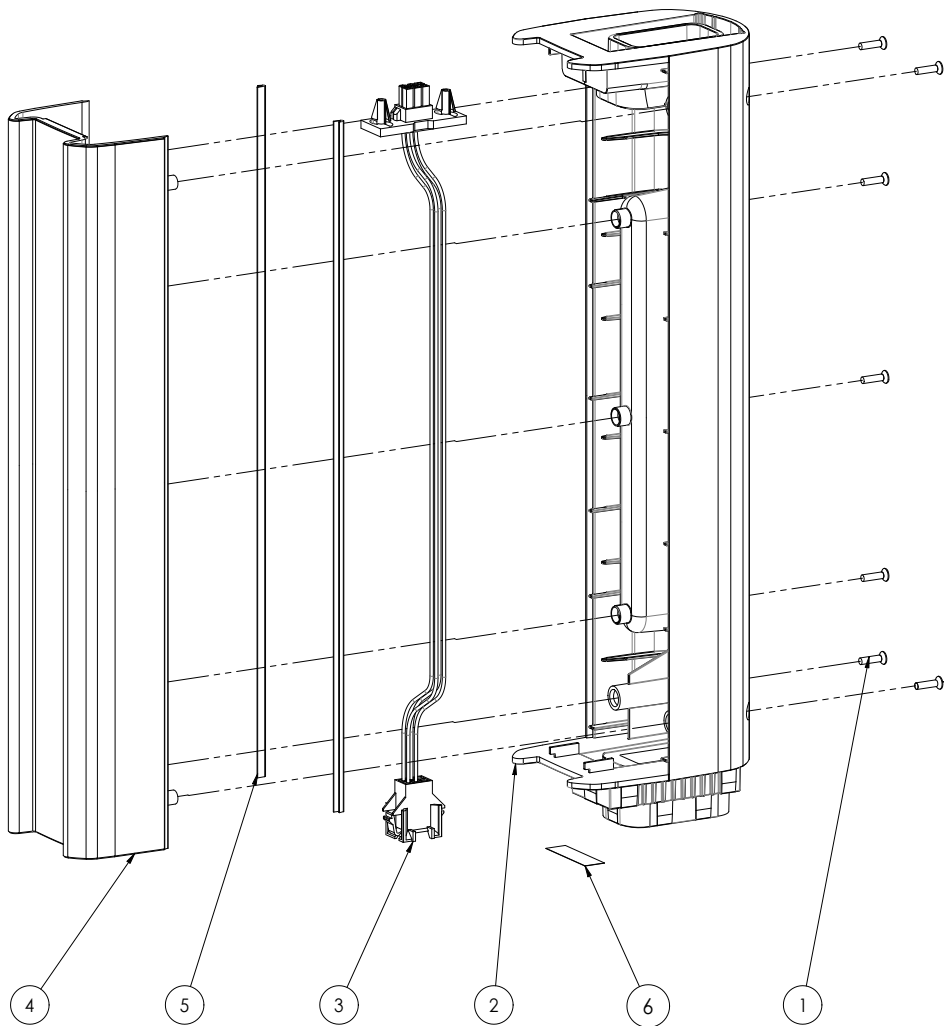

Figure 5. L1 Pro16 Extension Exploded View

# MAIN-I/O PCB PARTS LIST

## Resistors

Reference Designator	Description	Material Number	Note
R103	RES, THICK FILM, 0603, 0.1W, 1%, 5.6K	857326-0166	
R113	RES, THICK FILM, 0402, 0.063W, 1%, 6.8K	857326-0084	
R116, R172, R320, R327, R329, R336, R367, R371, R387, R389-R390, R393, R396, R398, R422	RES, THICK FILM, 0402, 0.063W, 1%, 10 OHM	857326-0089	
R118, R167	RES, THICK FILM, 0402, 0.063W, 1%, 22K	857326-0045	
R150, R286, R314, R318, R322, R414, R231A, R231B, R248A, R248B	RES, THICK FILM, 0603, 0.1W, 1%, 10K	857326-0093	
R160-R161	RES, THICK FILM, 0603, 0.1W, 1%, 33 OHM	857326-0146	
R169, R179	RES, THICK FILM, 0402, 0.063W, 1%, 100K	857326-0022	
R186	RES, THICK FILM, 0402, 0.063W, 1%, 200 OHM	857326-0037	
R196A, R196B, R205A, R205B	RES, THICK FILM, 0603, 0.1W, 1%, 1.5K	857326-0108	
R197A, R197B, R206A, R206B	RES, THICK FILM, 0603, 0.1W, 1%, 22 OHM	857326-0130	
R199A, R199B, R203A, R203B, R219A, R219B, R240A, R240B	RES, THICK FILM, 0603, 0.1W, 1%, 1M	857326-0095	
R1-R2, R5-R8, R16-R29, R32-R34, R91, R94, R108-R111, R119-R121, R137, R140, R153, R268, R293, R296-R297, R312-R313, R316, R321, R338, R358-R359, R361-R362, R369, R394, R399, R401-R404, R428-R430, R432-R434, R436-R437, R440, R442, R444-R445, R449-R452, R468	JUMPER, CHIP, 0402	857326-0217	
R200A, R200B, R204A, R204B	RES, THICK FILM, 0603, 0.1W, 1%, 10M	857326-0096	
R214A, R214B, R237A, R237B	RES, THICK FILM, 0603, 0.1W, 1%, 3K	857326-0140	
R215A, R215B, R223A, R223B, R245A, R245B, R254A, R254B	RES, THICK FILM, 0603, 0.1W, 1%, 1.2K	857326-0100	
R216A, R216B, R224A, R224B, R246A, R246B, R255A, R255B	RES, THICK FILM, 0603, 0.1W, 1%, 24 OHM	857326-0133	
R221A, R221B, R238A, R238B	RES, THICK FILM, 0603, 0.1W, 1%, 3.6K	857326-0149	
R222A, R222B, R242A, R242B	RES, THICK FILM, 0603, 0.1W, 1%, 330 OHM	857326-0143	
R226A, R226B, R235A, R235B	RES, THICK FILM, 0603, 0.1W, 1%, 6.8K	857326-0171	

# MAIN-I/O PCB PARTS LIST

Resistors (continued)

Reference Designator	Description	Material Number	Note
R229A, R229B	RES, THICK FILM, 0603, 0.1W, 1%, 220 OHM	857326-0126	
R230A, R230B	RES, THICK FILM, 0603, 0.1W, 1%, 2.1K	857326-0124	
R250A, R250B, R251A, R251B	RES, THICK FILM, 0603, 0.1W, 1%, 150 OHM	857326-0107	
R258A, R258B, R259A, R259B	RES, THICK FILM, 0603, 0.1W, 1%, 267 OHM	857326-0134	
R263A, R263B	RES, THICK FILM, 0603, 0.1W, 1%, 56 OHM	857326-0168	
R265A, R265B	RES, THICK FILM, 0402, 0.063W, 1%, 390 OHM	857326-0063	
R266A, R266B	RES, THICK FILM, 0603, 0.1W, 1%, 1.8K	857326-0115	
R267	RES, THICK FILM, 0402, 0.063W, 1%, 180K	857326-0036	
R272	RES, THICK FILM, 0603, 0.1W, 1%, 30.9K	857326-0142	
R274	RES, THICK FILM, 0402, 0.063W, 1%, 374K	857326-0062	
R275, R283	RES, THICK FILM, 0402, 0.063W, 1%, 41.2K	857326-0064	
R276	RES, THICK FILM, 0402, 0.063W, 1%, 32.4K	857326-0056	
R282	RES, THICK FILM, 0603, 0.1W, 1%, 210K	857326-0125	
R285	RES, THICK FILM, 0603, 0.1W, 1%, 1.3 OHM	857326-0183	
R289	RES, THICK FILM, 0603, 0.1W, 1%, 68K	857326-0172	
R290	RES, THICK FILM, 0402, 0.063W, 1%, 2K	857326-0038	
R294	RES, THICK FILM, 0603, 0.1W, 1%, 3.01K	857326-0141	
R295	RES, THICK FILM, 0603, 0.1W, 1%, 4.7 OHM	857326-0185	
R3, R9-R14, R30, R125-R127, R133-R134, R138-R139, R141-R149, R151-R152, R154-R158, R162, R164-R165, R170-R171, R177, R181-R185, R279-R280, R347-R357, R360, R365, R368, R372-R374, R376-R378, R380-R382, R388, R395, R416, R447-R448, R453, R455	RES, THICK FILM, 0402, 0.063W, 1%, 33 OHM	857326-0058	
R301	RES, THICK FILM, 0805, 0.125W, 5%, 4.7 OHM	857326-0194	
R303, R311	RES, THICK FILM, 0603, 0.1W, 1%, 511K	857326-0164	
R304	RES, THICK FILM, 0402, 0.063W, 1%, 453K	857326-0068	
R305, R317	RES, THICK FILM, 0603, 0.1W, 1%, 105K	857326-0097	
R31, R269, R271, R273, R287, R298-R300, R302, R307-R310	JUMPER, CHIP, 0805	857326-0219	
R319	RES, THICK FILM, 0603, 0.1W, 1%, 13.7K	857326-0105	
R324C, R324D, R332C, R332D, R333C, R333D, R341C, R341D	RES, THICK FILM, 0603, 0.1W, 1%, 4.99K	857326-0160	
R35, R53	RES, THICK FILM, 0603, 0.1W, 1%, 28K	857326-0137	

# MAIN-I/O PCB PARTS LIST

Resistors (continued)

Reference Designator	Description	Material Number	Note
R36, R43, R57, R65, R198A, R198B, R207A, R207B	RES, THICK FILM, 0805, 0.125W, 1%, 100 OHM	857326-0186	
R364, R195A, R195B, R202A, R202B, R208A, R208B, R209A, R209B, R211A, R211B, R247A, R247B, R252A, R252B, R253A, R253B, R257A, R257B, R260A, R260B	RES, THICK FILM, 0603, 0.1W, 1%, 1K	857326-0092	
R37, R50, R54, R68	RES, THICK FILM, 0603, 0.1W, 1%, 14K	857326-0106	
R375, R379, R383	RES, THICK FILM, 0603, 0.1W, 1%, 560 OHM	857326-0165	
R38, R41	RES, THICK FILM, 0603, 0.1W, 1%, 20K	857326-0120	
R39, R45, R55, R62	RES, THICK FILM, 0603, 0.1W, 1%, 120K	857326-0102	
R397, R425	RES, THICK FILM, 0402, 0.063W, 1%, 4.7K	857326-0070	
R4, R15, R88, R99, R114, R117, R130, R277, R292, R370, R385, R400, R424, R256A, R256B, R262A, R262B, R291A, R291B	JUMPER, CHIP, 0603	857326-0218	
R40, R46, R56, R63, R105, R217A, R217B, R220A, R220B, R225A, R225B, R239A, R239B, R241A, R241B, R243A, R243B	RES, THICK FILM, 0603, 0.1W, 1%, 10 OHM	857326-0181	
R406	RES, THICK FILM, 0603, 0.1W, 1%, 68.1 OHM	857326-0173	
R413	RES, THICK FILM, 0603, 0.1W, 1%, 750 OHM	857326-0174	
R42, R49, R59, R67, R163, R166, R210A, R210B, R232A, R232B	RES, THICK FILM, 0603, 0.1W, 1%, 2.2K	857326-0127	
R431	RES, THICK FILM, 0402, 0.063W, 1%, 2.2K	857326-0044	
R44, R47, R60, R64, R281, R391-R392, R418, R212A, R212B, R218A, R218B, R228A, R228B, R244A, R244B, R249A, R249B, R261A, R261B	RES, THICK FILM, 0603, 0.1W, 1%, 4.7K	857326-0155	
R462-R463, R464A, R464B	RES, THICK FILM, 0402, 0.063W, 1%, 1.5K	857326-0030	
R466A, R466B, R467A, R467B	RES, THICK FILM, 0402, 0.063W, 1%, 360 OHM	857326-0059	
R48, R66, R80, R86, R159, R233A, R233B, R74C, R74D, R77C, R77D	RES, THICK FILM, 0603, 0.1W, 1%, 47K	857326-0156	
R51, R69	RES, THICK FILM, 0603, 0.1W, 1%, 2.4K	857326-0132	
R52, R70, R191, R236A, R236B	RES, THICK FILM, 0402, 0.063W, 1%, 1K	857326-0020	
R58, R61, R173, R270, R306, R315, R323, R366, R415, R227A, R227B, R234A, R234B	RES, THICK FILM, 0603, 0.1W, 1%, 100K	857326-0094	

# MAIN-I/O PCB PARTS LIST

## Resistors (continued)

Reference Designator	Description	Material Number	Note
R71, R83-R84, R97	RES, THICK FILM, 0603, 0.1W, 1%, 18K	857326-0116	
R72, R75, R79, R89, R92, R96, R284, R201A, R201B, R264A, R264B, R325C, R325D, R328C, R328D, R331C, R331D, R334C, R334D, R337C, R337D, R340C, R340D	RES, THICK FILM, 0603, 0.1W, 1%, 100 OHM	857326-0091	
R73, R78, R90, R95, R326C, R326D, R330C, R330D, R335C, R335D, R339C, R339D	RES, THICK FILM, 0603, 0.1W, 1%, 6.2K	857326-0170	
R76, R93	RES, THICK FILM, 0603, 0.1W, 1%, 47 OHM	857326-0159	
R81-R82, R85, R87	RES, THICK FILM, 0603, 0.1W, 1%, 470 OHM	857326-0154	
R98, R102, R104, R107, R112, R122, R176, R180, R187-R190, R192-R193, R342-R346, R426-R427	RES, THICK FILM, 0402, 0.063W, 1%, 10K	857326-0021	

## Capacitors

Reference Designator	Description	Material Number	Note
C1, C13, C15-C16, C20-C21, C57-C59, C62-C64, C89, C93, C97, C99, C121, C124, C199, C208, C212-C213, C224, C226-C227, C236-C237, C239-C240, C252-C253, C293-C294, C134A, C134B, C135A, C135B, C136A, C136B, C137A, C137B, C148A, C148B, C149A, C149B, C150A, C150B, C151A, C151B, C174A, C174B, C269C, C269D, C271C, C271D	CAP, X7R, 0402, 25V, 10%, 0.1uF, COMM	718866-104K1E	
C104-C105, C107-C108, C122-C123, C192-C193, C230-C231, C288-C289	CAP, X7R, 0603, 6.3V, 10%, 4.7uF, COMM	718875-475K0J	
C11, C96, C119	CAP, X7R, 0603, 6.3V, 10%, 1uF, COMM	718875-105K0J	
C12, C23, C26, C32, C34, C36, C40-C41, C48, C51, C53, C68, C87, C91	CAP, EL, SMT, 105C, 16V, 20%, 22uF, COMM	856752- 220M1CBB	
C125	CAP, C0G, 0402, 50V, 5%, 1000pF, COMM	766718-102J1H	
C138A, C138B, C145A, C145B	CAP, C0G, 1206, 50V, 5%, 0.1uF, COMM	852048-104J1H	
C141A, C141B, C157A, C157B, C167A, C167B, C179A, C179B	CAP, C0G, 0603, 50V, 5%, 2700pF, COMM	780788-272J1H	
C142A, C142B, C144A, C144B, C161A, C161B, C172A, C172B	CAP, EL, LOW Z, SMT, 63V, 20%, 22uF, COMM	856727- 220M1JCD	

# MAIN-I/O PCB PARTS LIST

Capacitors (continued)

Reference Designator	Description	Material Number	Note
C158A, C158B, C175A, C175B	CAP, C0G, 0603, 50V, 5%, 270pF, COMM	780788-271J1H	
C162A, C162B	CAP, EL, SMT, 105C, 10V, 20%, 1000uF, COMM	856752-102M1AED	
C165A, C165B	CAP, C0G, 0603, 50V, 5%, 10pF, COMM	780788-100J1H	
C168A, C168B, C169A, C169B	CAP, X7R, FLEXTERM, 1206, 100V, 10%, 2.2uF, COM	774196-225K2A	
C17, C22, C66, C72, C86, C309	CAP, X5R, 0402, 25V, 20%, 1uF, COMM	716994-105M1E	
C181A, C181B, C186A, C186B, C90A, C90B	CAP, X7R, 0603, 50V, 10%, 0.1uF, COMM	718875-104K1H	
C190-C191, C210-C211, C217-C218, C233-C234, C243-C244, C250-C251	CAP, X5R, 0603, 25V, 10%, 4.7uF, COMM	718835-475K1E	
C194	CAP, X7R, 0805, 100V, 10%, 0.1uF, COMM	763872-104K2A	
C195	CAP, EL, SMT, 105C, 100V, 20%, 33uF, COMM	856752-330M2AED	
C196, C205, C225, C228, C235, C238, C245, C310	CAP, EL, SMT, 105C, 25V, 20%, 100uF, COMM	856752-101M1ECC	
C2, C14, C18-C19, C98, C101, C132, C215, C249, C152A, C152B, C153A, C153B, C183A, C183B, C184A, C184B	CAP, X5R, 0603, 10V, 10%, 10uF, COMM	718835-106K1A	
C204	CAP, C0G, 0603, 50V, 5%, 330pF, COMM	780788-331J1H	
C209	CAP, X7R, 0603, 16V, 10%, 0.47uF, COMM	718875-474K1C	
C229	CAP, C0G, 0402, 50V, 5%, 22pF, COMM	766718-220J1H	
C241	CAP, X7R, 0603, 50V, 10%, 0.22uF, COMM	718875-224K1H	
C242	CAP, C0G, 0603, 50V, 5%, 82pF, COMM	780788-820J1H	
C24-C25, C28-C29, C43-C44, C46-C47, C73, C77-C78, C82, C140A, C140B, C143A, C143B, C166A, C166B, C260C, C260D, C263C, C263D	CAP, C0G, 0603, 50V, 5%, 470pF, COMM	780788-471J1H	
C27, C35, C42, C52, C155A, C155B, C164A, C164B, C170A, C170B, C173A, C173B	CAP, C0G, 0603, 50V, 5%, 100pF, COMM	780788-101J1H	
C291-C292	CAP, C0G, 0402, 50V, 5%, 15pF, COMM	766718-150J1H	
C30, C39, C49, C56	CAP, X7R, 0402, 50V, 10%, 0.1uF, COMM	718866-104K1H	
C65, C69, C83, C95, C100, C102, C106, C109-C118, C120, C126-C131, C202, C214, C273-C277, C285-C287, C304	CAP, X7R, 0402, 50V, 10%, 10000pF, COMM	718866-103K1H	



# MAIN-I/O PCB PARTS LIST

Capacitors (continued)

Reference Designator	Description	Material Number	Note
C67, C76, C79, C88, C185A, C185B, C187A, C187B, C188A, C188B, C189A, C189B	CAP, C0G, 0402, 50V, 5%, 100pF, COMM	766718-101J1H	
C71, C85, C216, C258C, C258D, C266C, C266D	CAP, C0G, 0603, 50V, 5%, 1000pF, COMM	780788-102J1H	
C8, C10, C60-C61, C74-C75, C80-C81, C203, C133A, C133B, C146A, C146B, C154A, C154B, C163A, C163B, C177A, C177B, C182A, C182B, C255C, C255D, C261C, C261D, C262C, C262D, C268C, C268D	CAP, C0G, 0603, 50V, 5%, 220pF, COMM	780788-221J1H	

## Diodes

Reference Designator	Description	Material Number	Note
D15	DIODE, RECT, 200V, 1A,ESH1DM, SMA	849894-0100	
D17	DIODE, SCHOTTKY, 2A, 60V, SOD123F	852398-0010	
D18, D25	DIODE, SCHOTTKY, 40V, 1A, SS14L, FLSMA	855980-0040	
D1-D4, D19, D12A, D12B, D13A, D13B, D14A, D14B, D9A, D9B	DIODE, SW, 75V, 0.3A, SOT-23, BAV99	747976-0010	
D20	DIODE, TVS, BIDIR, DUAL, 24V, ESDCAN01, SOT23, AUTO	855760-0010	
D22, D26, D10A, D10B, D11A, D11B	DIODE, SWITCHING, 100V, 0.15A, SOD323F	856395-0010	
D37A, D37B, D38A, D38B	DIODE, TVS, 58V, 400W, BI-DIR, SMAJ58CA	310546-058	
D43	DIODE, SCHOTTKY, 30V, BAT54A, SOT-23	330427-0020	
D5-D6, D8, D16, D21, D23-D24, D27-D34, D35A, D35B, D36A, D36B	VARISTOR, MULTILAYER, 0402, 130pF, 12V	855757-120M131	
LED15	DIODE, LED, 0603, BLUE,V ERT	851299-0010	
LED17	DIODE, LED, 0606, WHITE, RED, VERT	851297-0010	
LED1-LED3, LED5, LED8, LED10-LED14, LED16	DIODE, LED, 0603, WHITE, VERT	851300-0010	
LED4, LED6-LED7, LED9	DIODE, LED, 0603, WHITE, GREEN, VERT	851298-0010	

## MAIN-I/O PCB PARTS LIST

Inductors			
Reference Designator	Description	Material Number	Note
L1	INDUCTOR, WW, CM, 1206, 0.2A, 2200 OHM, COMM	855607-222	
L2	BEAD, FERRITE, PWR, 0603, 1.3A, 600 OHM, COMM	852198-601	
L22	BEAD, FERRITE, 0402, 0.1A, 1800 OHM, COMM	840686-182D	
L29	INDUCTOR, POWER, SMT, 1.2A,30%, 2.2uH, COMM	852851-2R2N	
L30	INDUCTOR, POWER, SMT, 0.7A, 20%, 220uH, COMM	852883-221M	
L31, L33-L34	INDUCTOR, POWER, SMT, 2.5A, 20%, 22uH, COMM	853388-220M	
L7-L14, L25A, L25B, L26A, L26B, L27A, L27B, L28A, L28B	BEAD, FERRITE, 0402,0.25A, 1.1 OHM, Z=1K	371767-0010	

### Transistors

Reference Designator	Description	Material Number	Note
Q14A, Q14B, Q15A, Q15B, Q16A, Q16B, Q17A, Q17B, Q18A, Q18B, Q19A, Q19B, Q20A, Q20B, Q21A, Q21B	TRANSISTOR, PNP, 40V, 0.6A, SOT-23, MMBT4403	260354-001	
Q1-Q4	TRANSISTOR, NPN, 20V, 0.3A, 2SC3326-B, SC-59	856177-0020	
Q24	TRANSISTOR, MFET, N-CH, 60V, 2.1A, SOT23	856158-0010	
Q25	TRANSISTOR, MFET, P-CH, -3.8A, -30V, SOT23	852237-0010	
Q27	TRANSISTOR, MFET, P-CH, -180mA, -60V, SOT23	852238-0010	
Q29-Q32, Q10A, Q10B, Q11A, Q11B	TRANSISTOR, DUAL, COMP, 40V, 0.6A, 200mW, SOT-363	850060-0100	
Q5	XSISTOR, BPLR, P, 40V, 200mA, SOT23	148596	
Q7, Q26, Q28, Q22A, Q22B, Q23A, Q23B	TRANSISTOR, NPN, 40V, 0.2A, MMBT3904, SOT323	195357	
Q9	TRANSISTOR, MFET, N-CH, 0.23A, 60V, SOT363	852240-0010	

# MAIN-I/O PCB PARTS LIST

Integrated Circuit

Reference Designator	Description	Material Number	Note
U1	IC, ADC, AUDIO, 4CH, TLV320ADC5140, 24WQFN	855431-0010	
U10	IC, DAC, 24bit, 4CH, PCM4104, 48TQFP	855451-0010	
U13	IC, uC, CORTEX-M0, 256KB, 32F091, 100LQFP	852528-VCT6	
U14	IC, V-DETECT, 2.93V, APX809S-29, SOT-23	856551-0010	3 
U15A, U15B	IC, ANALOG SWITCH, SPST, 16TSSOP, DG411	852384-0010	
U16	IC, VREG, SW, BUCK, 2AD, ADJ, 62084, WSON8	791774-0020	
U17	IC, VOLT REG CTRL, SW, N-CH, LM3486, 10VSSOP	855905-0010	
U18	IC, DCDC CONV, BUCK, PWM, 1 A, TSOT, LV2843	842705-0010	
U20, U23	IC, DCDC CONV, STEP DOWN, 2A, 28V, TPS54202H	842669-0010	
U21	IC, VREG, LIN, POS, 0.5A, 15V, 78M15C, DPAK	856494-0010	
U22	IC, VREG, LIN, NEG, 0.5A, 15V, 79M15C, DPAK	856495-0010	
U26	IC, LOGIC, UHS BUFFER, DUAL, 5V, SC70	763299-0010	
U28	IC, RCVR, RS485/RS422, MAX3283E, SOT23-6	855915-0083	
U2A, U2B	IC, OP AMP, DUAL, TL072	187619-001	
U6	IC, LED DRIVER, RGB, 12BIT, 18-CH, VQFN32	852362-0018	
U7-U8, U11	IC, OP AMP, DUAL, LOW-NOI, NJM2068M-TE2, DMP8	855835-01A2	
U9, U25C, U25D, U3A, U3B, U4A, U4B, U5A, U5B	IC, OP AMP, DUAL, NJM4580E-TE2, SOP8, 90DEG	855786-01A2	

# MAIN-I/O PCB PARTS LIST

Miscellaneous

Reference Designator	Description	Material Number	Note
CN1	CONN, RECP, 1.27mm C, 16P, 2R, R, SMT, ST	847826-0016	
J1	CONN, RECP, 1.27mm C, 10P, 2R, R, SMT, ST	847826-0010	
J16	CONN, HDR, 1.5mm C, 11P, 1R, P, SMT, ST, BEIGE	847746-0110	
J17	CONN, HDR, 1.5mm C, 10P, 1R, P, SMT, ST, BEIGE	847746-0100	
J18	CONN, HDR, 1.5mm C, 8P, 1R, P, SMT, ST, BEIGE	847746-0080	
J19A, J19B	CONN, IO, XLR, 3POLE, ST, R, PCB Mount	850870-0010	
J2	CONN, HDR, 2.54mm C, 6P, 2R, P, TH, ST, 6.9H	853418-0006	
J22	CONN, RECP, 2.54mm C, 28P, 2R, R, SMT, ST, BL, Au	847748-0028	
J4	CONN, IO, 6.35MM STERIO JACK, R, ST, PCB MOUN	849858-0010	3 
J5	CONN, IO, 3POLE XLR, P, Sel Gold	763327-0120	
SW1-SW2, SW4, SW6-SW10	SWITCH, TACT, 12V, 50mA, 250gf	850862-0010	
SW3	SWITCH, TACT, 15V, 20mA, 320GF	854394-0010	
T1	TRANSFORMER, A UDIO, DIGITAL, DIL, 1mH	856463-0010	
USB1	CONN, IO, TYPE C, 24P, R, SMT, RA, TMOUNT, CH2.2	853416-0010	

# POWER-AMP PCB PARTS LIST

## Resistors

Reference Designator	Description	Material Number	Note
R108	RES, THICK FILM, 0603, 0.1W, 1%, 30.9K	857326-0142	
R109	RES, THICK FILM, 0603, 0.1W, 1%, 133K	857326-0104	
R10X, R10Y, R10Z, R11X, R11Y, R11Z	RES, THICK FILM, 0603, 0.1W, 1%, 22 OHM	857326-0130	
R112, R143, R181	RES, THICK FILM, 0603, 0.1W, 1%, 4.7K	857326-0155	
R113, R147, R16X, R16Y, R16Z	RES, THICK FILM, 0603, 0.1W, 1%, 3.3K	857326-0144	
R115, R125	RES, THICK FILM, 0805, 0.125W, 1%, 33 OHM	857326-0190	
R116, R128, R210, R213	RES, THICK FILM, 0603, 0.1W, 1%, 1M	857326-0095	
R120	RES, THICK FILM, 0603, 0.1W, 1%, 18.2K	857326-0117	
R129	RES, THICK FILM, 0603, 0.1W, 1%, 75 OHM	857326-0177	
R12X, R12Y, R12Z, R14X, R14Y, R14Z, R7X, R7Y, R7Z, R9X, R9Y, R9Z	RES, THICK FILM, 0603, 0.1W, 1%, 8.2K	857326-0178	
R132	RES, THICK FILM, 0603, 0.1W, 1%, 20 OHM	857326-0123	
R138, R153	RES, THICK FILM, 0603, 0.1W, 1%, 75K	857326-0176	
R140-R141, R150, R167, R263	RES, THICK FILM, 0603, 0.1W, 1%, 1K	857326-0092	
R144	RES, THICK FILM, 0603, 0.1W, 1%, 16.5K	857326-0113	
R145	RES, THICK FILM, 0603, 0.1W, 1%, 51K	857326-0163	
R149	RES, THICK FILM, 0603, 0.1W, 1%, 43K	857326-0153	
R151, R265	RES, THICK FILM, 0603, 0.1W, 1%, 2K	857326-0119	
R156	RES, THICK FILM, 0603, 0.1W, 1%, 68K	857326-0172	
R157, R13X, R13Y, R13Z, R4X, R4Y, R4Z	RES, THICK FILM, 0603, 0.1W, 1%, 4.7 OHM	857326-0185	
R158	RES, THICK FILM, 0603, 0.1W, 1%, 3.01K	857326-0141	
R159-R161	RES, THICK FILM, 1206, 0.25W, 1%, 240K	857326-0205	
R15X, R15Y, R15Z	RES, THICK FILM, 0603, 0.1W, 1%, 1.8K	857326-0115	
R168, R177-R179, R242	RES, THICK FILM, 1206, 0.25W, 1%, 2.2 OHM	857326-0214	3 ⚠
R169-R170, R182, R211, R222X, R222Y, R222Z	RES, THICK FILM, 0603, 0.1W, 1%, 47K	857326-0156	
R171, R187	RES, THICK FILM, 1206, 0.25W, 1%, 47 OHM	857326-0207	
R174	RES, THICK FILM, 0805, 0.125W, 1%, 100 OHM	857326-0186	
R175, R241	RES, THICK FILM, 0603, 0.1W, 1%, 1.5K	857326-0108	
R176	RES, THICK FILM, 0603, 0.1W, 1%, 470 OHM	857326-0154	
R186	RES, THICK FILM, 0603, 0.1W, 1%, 7.5K	857326-0175	
R193-R194	RES, THICK FILM, 0603, 0.1W, 1%, 330K	857326-0145	
R196, R198-R199	RES, THICK FILM, 0603, 0.1W, 1%, 470K	857326-0157	
R19X, R19Y, R19Z, R20X, R20Y, R20Z, R21X, R21Y, R21Z, R22X, R22Y, R22Z	RES, THICK FILM, 1206, 0.25W, 1%, 10K	857326-0196	

# POWER-AMP PCB PARTS LIST

Resistors (continued)

Reference Designator	Description	Material Number	Note
R203X	RES, THICK FILM, 0603, 0.1W, 1%, 330 OHM	857326-0143	
R203Y	RES, THICK FILM, 0603, 0.1W, 1%, 360 OHM	857326-0148	
R203Z	RES, THICK FILM, 0603, 0.1W, 1%, 390 OHM	857326-0150	
R207	RES, THICK FILM, 0603, 0.1W, 1%, 47 OHM	857326-0159	
R209	RES, THICK FILM, 1206, 0.25W, 1%, 680 OHM	857326-0210	
R214-R217	RES, THICK FILM, 0805, 0.125W, 1%, 39K	857326-0191	
R218, R249, R5X, R5Y, R5Z	RES, THICK FILM, 0603, 0.1W, 1%, 2.2K	857326-0127	
R229	RES, THICK FILM, 0603, 0.1W, 1%, 130K	857326-0103	
R230	RES, THICK FILM, 1206, 0.25W, 1%, 1.3 OHM	857326-0213	
R231	RES, THICK FILM, 0603, 0.1W, 1%, 150K	857326-0110	
R239	RES, THICK FILM, 0603, 0.1W, 1%, 220K	857326-0129	
R23X, R23Y, R23Z, R24X, R24Y, R24Z	RES, THICK FILM, 1206, 0.25W, 1%, 20 OHM	857326-0202	
R253X, R253Y, R253Z	RES, THICK FILM, 0603, 0.1W, 1%, 34K	857326-0147	
R259X, R259Y, R259Z	RES, THICK FILM, 0603, 0.1W, 1%, 20K	857326-0120	
R26, R33, R35, R41, R44, R51, R53-R54	RES, THICK FILM, 0603, 0.1W, 1%, 6.8K	857326-0171	
R268X, R268Y, R268Z	RES, THICK FILM, 0603, 0.1W, 1%, 300 OHM	857326-0139	
R27, R31, R36, R39, R45, R49	RES, THICK FILM, 0603, 0.1W, 1%, 3.9K	857326-0151	
R28, R32, R37, R40, R46, R50, R122-R123	RES, THICK FILM, 0603, 0.1W, 1%, 2.4K	857326-0132	
R29-R30, R47-R48, R52, R55, R66, R75, R78, R80, R91, R95, R104, R119, R124, R131, R146, R152, R165, R184, R189, R191, R197, R200, R208, R219-R220, R237, R240, R248, R250, R254-R255, R261, R267, R18X, R18Y, R18Z, R252X, R252Y, R252Z, R25X, R25Y, R25Z, R8X, R8Y, R8Z	RES, THICK FILM, 0603, 0.1W, 1%, 10K	857326-0093	
R2X, R2Y, R2Z	RES, THICK FILM, 0603, 0.1W, 1%, 27K	857326-0136	
R34, R43, R59, R65, R85, R90, R114, R121, R126, R130, R163, R190, R212, R247, R1X, R1Y, R1Z	RES, THICK FILM, 0805, 0.125W, 5%, 4.7 OHM	857326-0194	
R38, R42, R103, R127, R195, R232-R234, R236, R257, R269-R271	JUMPER, CHIP, 0603	857326-0218	
R3X, R3Y, R3Z	RES, THICK FILM, 1206, 0.25W, 1%, 8.2K	857326-0211	
R56-R57, R62-R63, R148, R164, R166, R221	RES, THICK FILM, 1206, 0.25W, 1%, 825K	857326-0212	3 
R58, R84, R155	RES, THICK FILM, 0805, 0.125W, 1%, 22 OHM	857326-0189	

# POWER-AMP PARTS LIST

Resistors (continued)

Reference Designator	Description	Material Number	Note
R60, R76-R77, R87-R88, R106, R204-R205	RES, THICK FILM, 0402, 0.063W, 1%, 2.2K	857326-0044	
R61, R105	RES, METAL FOIL, 1206, 1W, 1%, 0.01 OHM	755170-R010F	
R64, R67	RES, METAL FOIL, 1206, 1W, 1%, 0.005 OHM	755170-R005F	
R68, R79	JUMPER, CHIP, 1206	857326-0220	3 ⚠
R69, R94, R173, R180, R188, R201-R202, R238, R251, R256, R258, R266	RES, THICK FILM, 0603, 0.1W, 1%, 100K	857326-0094	
R6X, R6Y, R6Z	RES, THICK FILM, 1206, 0.25W, 1%, 49.9K	857326-0208	
R70-R71, R117-R118, R133-R134	RES, THICK FILM, 1206, 0.25W, 1%, 220 OHM	857326-0203	
R72, R223-R224	RES, THICK FILM, 1206, 0.25W, 1%, 20K	857326-0200	
R73-R74, R142, R262	RES, THICK FILM, 0603, 0.1W, 1%, 100 OHM	857326-0091	
R81-R82, R92, R111, R135-R137, R183, R226-R228, R235	RES, THICK FILM, 1206, 0.25W, 1%, 2.2M	857326-0204	
R83, R86, R97, R102	RES, THICK FILM, 1206, 0.25W, 1%, 2 M	857326-0201	
R89, R100-R101	RES, THICK FILM, 1206, 0.25W, 1%, 3.3M	857326-0206	
R93, R98, R225, R260, R264	RES, THICK FILM, 0603, 0.1W, 1%, 22K	857326-0128	
R96, R154, R162	JUMPER, CHIP, 0805	857326-0219	
R99, R17X, R17Y, R17Z	RES, THICK FILM, 0603, 0.1W, 1%, 220 OHM	857326-0126	
RT1	VARISTOR, METAL OXIDE, DIA 14mm, 300Vrms	856832-3000D	3 ⚠
RT2	THERMISTOR, NTC, ICL, BULK, 20%, 10 ohm	856032-100MB	3 ⚠
RT3-RT4	THERMISTOR, NTC, 0603, 3380K, 1%, 10K	855644-103F	

## Capacitors

Reference Designator	Description	Material Number	Note
C103, C189	CAP, X7R, 0805, 100V, 10%, 0.033uF, COMM	763872-333K2A	
C106, C113	CAP, X7R, 0603, 100V, 10%, 220pF, COMM	718875-221K2A	
C108	CAP, X7R, 0603, 50V, 10%, 0.015uF, COMM	718875-153K1H	
C114	CAP, C0G, 0603, 50V, 5%, 100pF, COMM	780788-101J1H	
C119, C128, C174	CAP, EL, POLYMER, SMT, 25V, 20%, 150uF, COMM	857020-151M1E-BE	
C124, C182	CAP, X7R, 0805, 100V, 10%, 0.01uF, COMM	763872-103K2A	
C12X, C12Y, C12Z, C1X, C1Y, C1Z, C5X, C5Y, C5Z	CAP, X5R, 0603, 25V, 20%, 10uF, COMM	718835-106M1E	
C135	CAP, X7R, 0603, 50V, 10%, 0.047uF, COMM	718875-473K1H	
C14, C75, C81, C121, C127, C130, C196	CAP, X7R, 0603, 50V, 10%, 1uF, COMM	718875-105K1H	
C160-C168, C170-C172	CAP, X7R, 0402, 100V, 10%, 2200pF, COMM	718866-222K2A	

# POWER-AMP PCB PARTS LIST

Capacitors (continued)

Reference Designator	Description	Material Number	Note
C176, C197, C199, C201	CAP, EL, SMT, 105C, 16V, 20%, 10uF, COMM	856752- 100M1CAB	
C17X, C17Y, C17Z, C18X, C18Y, C18Z, C193X, C193Y, C193Z, C194X, C194Y, C194Z, C22X, C22Y, C22Z, C23X, C23Y, C23Z, C27X, C27Y, C27Z	CAP, X7R, 0603, 100V, 10%, 0.1uF, COMM	718875-104K2A	
C19, C72-C73, C78, C82, C94, C115-C118, C132-C133, C142-C143, C149-C150, C173, C10X, C10Y, C10Z, C3X, C3Y, C3Z, C7X, C7Y, C7Z	CAP, X5R, 0603, 25V, 10%, 4.7uF, COMM	718835-475K1E	
C24X, C24Y, C24Z	CAP, FILM, LS 5mm, AMMO, 5%, 100V, 1uF	329288-1004BJA	
C25X, C25Y, C25Z	CAP, X7R, 0805, 100V, 20%, 0.01uF, COMM	763872-103M2A	
C26X, C26Y, C26Z	CAP, C0G, 0805, 100V, 5%, 1000pF, COMM	763940-102J2A	
C28, C32, C34, C38, C42, C46	CAP, C0G, 0603, 50V, 5%, 680pF, COMM	780788-681J1H	
C29-C30, C43-C44, C152, C154, C156	CAP, C0G, 0603, 50V, 5%, 470pF, COMM	780788-471J1H	
C31, C37, C45	CAP, X7R, 0603, 50V, 10%, 3300pF, COMM	718875-332K1H	
C39, C77, C93, C151, C203	CAP, X7R, 0603, 50V, 5%, 10000pF, COMM	718875-103J1H	
C4, C11, C13, C35-C36, C40-C41, C104-C105, C110-C112, C125, C138, C140, C147, C183, C188, C190-C191	CAP, X7R, 0603, 50V, 10%, 0.1uF, COMM	718875-104K1H	
C48, C62, C64	CAP, X7R, HI VOLT, 0805, 630V, 10%, .01uF, COMM	852020-103K2J	
C49-C50	CAP, EL, SNAP-IN, 450V, 20%, 330uF	853707- 331M2WCC	3 
C52-C53, C120, C129, C141	CAP, EL, POLYMER, SMT, 25V, 20%, 47uF, COMM	857020- 470M1EAA	
C55, C67, C76, C177	CAP, FILM, PFC, 15mm, BULK 6mm, 630V, 10%, 1uF	856507- 105K2JBB	
C61, C123, C159	CAP, X7R, HI V, 1206, 1000V, 10%, 4700pF, COMM	852057-472K3A	
C65-C66	CAP, C0G, 0603, 50V, 5%, 47pF, COMM	780788-470J1H	
C68, C70-C71, C131, C139, C146, C6X, C6Y, C6Z, C8X, C8Y, C8Z, C9X, C9Y, C9Z	CAP, C0G, 0603, 50V, 5%, 1000pF, COMM	780788-102J1H	
C69, C101, C107	CAP, C0G, 0603, 50V, 5%, 220pF, COMM	780788-221J1H	
C74	CAP, X7R, 0603, 50V, 10%, 0.068uF, COMM	718875-683K1H	
C79	CAP, X7R, 0603, 16V, 10%, 0.47uF, COMM	718875-474K1C	
C80, C102	CAP, C0G, 0805, 250V, 5%, 100pF, COMM	763940-101J2E	



# POWER AMP PCB PARTS LIST

Capacitors (continued)

Reference Designator	Description	Material Number	Note
C83	CAP, C0G, 0603, 50V, 5%, 330pF, COMM	780788-331J1H	
C84, C95, C134X, C134Y, C134Z, C144X, C144Y, C144Z, C15X, C15Y, C15Z, C16X, C16Y, C16Z, C20X, C20Y, C20Z, C21X, C21Y, C21Z	CAP, X7R, 0805, 100V, 10%, 0.47uF, COMM	763872-474K2A	
C85-C87, C96-C98	CAP, EL, LOW Z, 18x25mm, 80V, 20%, 820uF	853760-821M1K-GG	
C88, C91	CAP, X7R, HI VOLT, 0805, 500V, 10%, 220pF, COMM	852020-221K2H	
C89,C136-C137,C175	CAP, X7R, 0603, 100V, 10%, 1000pF, COMM	718875-102K2A	
C90	CAP, C0G, HI VOLT, 1206, 500V, 5%, 15pF, COMM	777098-150J2H	
C92	CAP, X7R, 0603, 50V, 10%, 0.22uF, COMM	718875-224K1H	
C99-C100	CAP, FILM, HI V, 15mm, BULK, 1000V, 5%, 0.68uF	856510-683J3ABB	
CX1-CX3	CAP, FILM, X2, LS 15mm, 305VAC, 20%, 0.47uF	310415-474MG	3 ⚠
CY1-CY2	CAP, CER, X1/Y1, Bulk 25mm, 10%, 330pF	855444-331KG	3 ⚠
CY3-CY4,CY6	CAP, CER, X1/Y1, Bulk 5mm, 20%, 1000pF	855444-102MN	3 ⚠
CY5	CAP, CER, X1/Y1, Bulk 25mm, 10%, 470pF	855444-471KG	3 ⚠

## Diodes

Reference Designator	Description	Material Number	Note
BD1	DIODE, BRIDGE RECTIFIER, 25A, 800V, SIP	842301-0800	3 ⚠
D19-D21, D24	DIODE, RECT, S-FAST, 400V, 10A, TPMP10G, SMPC	855873-0400	
D23	DIODE, ZENER, 0.2W, 15V, 5%, SOD-323F	856094-15V0	
D25-D26	DIODE, ZENER, 0.5W, 2.4V, 2%, SOD-123F	856111-02V4	
D27	DIODE, RECT, ULTRAFast, 200V, 6A, TPUH6D, SMPC	855862-0200	
D28	DIODE, SCHOTTKY, 2A, 60V, SOD123F	852398-0010	
D29, D42, D45	DIODE, ZENER, 0.5W, 5%, 24V, SOD-123	174265-5252	
D3, D13-D14, D33, D35, D43-D44	DIODE, RECT, FAST, 1000V, 0.8A, RS1ML, FLSMA	856386-1000	
D30-D31	DIODE, RECT, FAST, 1000V, 1A	317066-1000	
D32, D34, D1X, D1Y, D1Z, D2X, D2Y, D2Z	DIODE, RECT, 200V, 1A, ESH1DM, SMA	849894-0100	
D36	DIODE, ZENER, 0.2W, 12V, 2%, SOD-323F	856105-12V0	
D39	DIODE, SW, 75V, 0.3A, SOT-23, BAV99	747976-0010	
D4, D12, D18, D22, D37-D38, D40, D41X, D41Y, D41Z, D5X, D5Y, D5Z	DIODE, SWITCHING, 100V, 0.15A, SOD323F	856395-0010	

# POWER AMP PCB PARTS LIST

## Diodes

Reference Designator	Description	Material Number	Note
D6X, D6Y, D6Z, D7X, D7Y, D7Z	DIODE, RECT, SUPERFAST, 200V, 1A, ES1D, SMA	856033-0200	
D9, D11, D15, D17	DIODE, SINGLE, 600V, 5A, RFNL58M6S, TO-252	849891-0010	
LED2-LED3, LED1X, LED1Y, LED1Z	DIODE, LED, 0603, 50mA, RED, VERT	851303-0010	
ZD3-ZD5	DIODE, ZENER, 0.2W, 5.1V, 5%, SOD-323F	856094-05V1	

## Transistors







Reference Designator	Description	Material Number	Note
Q1, Q3, Q6, Q8, Q10-Q11, Q13-Q14	TRANSISTOR, MFET, N-CH, 600V, 18A, DPAK	849830-0020	3 
Q12, Q18	TRANSISTOR, MFET, N-CH, 0.3A, 60V, SOT-23	356154-0010	
Q16	TRANSISTOR, MFET, P-CH, 4A, 30V, SOT23	357292-0020	
Q2, Q7, Q19-Q21, Q32	TRANSISTOR, PNP, 40V, 0.6A, SOT-23, MMBT4403	260354-001	
Q4	TRANSISTOR, NPN, 40V, 0.6A, SOT-23, 2222A	326376-0010	
Q5, Q15, Q17, Q22-Q26, Q30	TRANSISTOR, NPN, 40V, 0.2A, MMBT3904, SOT323	195357	
Q9	TRANSISTOR, NPN, 3A, 50V, SOT89	852881-0010	

## Integrated Circuit

Reference Designator	Description	Material Number	Note
U11, U16	IC, LIN REG, ADJ, SHUNT, TL431, 1%, SOT23-3	330361-1030	
U12	IC, DCDC CONV, BUCK, PWM, 1A, TSOT, LV2843	842705-0010	
U13	IC, VREG, LIN, POS, 5V, 78L05, SOT-89	856413-0010	
U14	IC, VREG, SW, FLYBACK CNTRLR, HF500-30, 7PDIP	855588-0010	
U17	IC, VREG, LIN, NEG, 0.1A, 5V, TS79L05CY, SOT-89	856536-0010	
U1X, U1Y, U1Z	IC, PWR AMP, CLASS D, IRS2092, 16SOIC-N	855546-0010	
U2X, U2Y, U2Z, U3X, U3Y, U3Z	TRANSISTOR, MFET, N, 150V, 12.6A, SIR622, SO8	847723-0100	
U4-U5	IC, OPERATIONAL AMPLIFIER, 8SO, NE5532	852382-0010	
U6, U10, U15, U18	IC, OPTOCOUPLER, EL817, 4SO	326344-0020	3 
U7	IC, PFC CONTROLLER, TRANS MODE, UCC28063	730085-0030	
U8	IC, SW, CNTRLR, HALF-BRIDGE, HR1001A, 16SOIC	855754-0010	
U9, U20	IC, OP AMP, DUAL, LM358, 8SOIC	856447-0010	

# POWER AMP PCB PARTS LIST

## Miscellaneous

Reference Designator	Description	Material Number	Note
F1	FUSE, 12A, 250V, SLO-BLO, 5x20mm, AXIAL	317834-123B	3 
J1	CONN, HDR, 3.96mm C, 2P, 1R, P, TH, RA, WHITE	847740-0020	
J2	CONN, HDR, 2.54mm C, 28P, 2R, P, TH, ST, 45.8H	847836-0028	
J3	CONN, HDR, 3.96mm C, 4P, 1R, P, TH, RA, WHITE	847740-0040	
J4	CONN, HDR, 3.96mm C, 2P, 1R, P, TH, ST, WHITE	847743-0020	
J5-J6	CONN, HDR, 1.25mm C, 4P, 1R, P, SMT, ST	845374-0401	
J7	CONN, HDR, 2mm C, 2P, 1R, P, SMT, ST	847747-0020	
K1	RELAY, POWER, 10A, 1a/1c, CLASS B INs	850873-0020	3 
L12	INDUCTOR, POWER, SMT, 2.5A, 20%, 22uH, COMM	853388-220M	
L2, L7	INDUCTOR, CUSTOM, RADIAL, 85uH	852652-0010	3 
L4-L6	INDUCTOR, CUSTOM, RADIAL, 15mm HEIGHT, 8.5mH	852653-0010	3 
T1	TRANSFORMER, CUSTOM, HTS-EEL25A	852657-0010	3 
T2	TRANSFORMER, SWITCH, CUSTOM, HTS-ER49B	852656-0010	3 

# VOLUME PCB PARTS LIST

## Resistors

Reference Designator	Description	Material Number	Note
R71-R72	RES, THICK FILM, 0402, 0.063W, 1%, 6.8K	857326-0084	
R73-R83	RES, THICK FILM, 0402, 0.063W, 1%, 10K	857326-0021	

## Capacitors

Reference Designator	Description	Material Number	Note
C1, C3, C8, C10, C12-C13	CAP, X7R, 0402, 25V, 10%, 0.1uF, COMM	718866-104K1E	
C14-C15	CAP, X5R, 0402, 25V, 20%, 1uF, COMM	716994-105M1E	
C2, C4	CAP, EL, SMT, 105C, 16V, 20%, 22uF, COMM	856752-220M1CBB	
C5-C6, C11, C16-C33	CAP, X7R, 0402, 50V, 10%, 10000pF, COMM	718866-103K1H	
C7, C9	CAP, X5R, 0603, 10V, 10%, 10uF, COMM	718835-106K1A	

## Diodes

Reference Designator	Description	Material Number	Note
D1-D8	VARISTOR, MULTILAYER, 0402, 130pF, 12V	855757-120M131	
LED1-LED33, LED35-LED38, LED40-LED41, LED43-LED53	DIODE, LED, 0603, WHITE, VERT	851300-0010	
LED34, LED39, LED42	DIODE, LED, 0603, RED, GREEN, VERT	851301-0010	

## Integrated Circuit

Reference Designator	Description	Material Number	Note
U1-U2	IC, LED DRIVER, RGB, 12BIT, 36-CH, VQFN46	852363-0036	

## Miscellaneous

Reference Designator	Description	Material Number	Note
J1	CONN, HDR, 1.5mm C, 10P, 1R, P, SMT, ST, BEIGE	847746-0100	
J2	CONN, HDR, 1.5mm C, 11P, 1R, P, SMT, ST, BEIGE	847746-0110	
L3-L12	BEAD, FERRITE, 0402, 0.1A, 1800 OHM, COMM	840686-182D	
SW1-SW3	ENCODER, ROTARY, SWITCH, XRE0126	850872-0010	

# DISASSEMBLY PROCEDURE

## L1 Pro16 Power Stand Procedures

**CAUTION:** The SMD integrated circuits used on the Main-I/O Board are extremely sensitive to ESD damage. Be sure to use an approved and tested ESD strap that is properly grounded to your work bench before attempting disassembly or repair of the L1 Pro16 Portable Line Array System.

### 1. Enclosure Bottom Removal

**1.1** Remove the Mid-high array and Array extension. Put the Power stand upside down. Figure 6.

**1.2** The PC sheets ① ② ③ ④ are secured with Pressure Sensitive Adhesive - use a spudger, lift the PC sheets up and grasp and pull them off. Figure 7.

**Re-assembly Note:** Be careful to not cause cosmetic damage to the unit.

Use the new PC sheets to ensure proper adhesion during reassembly.

**1.3** Remove the 12 screws securing the Enclosure bottom as indicated in Figure 8.



Figure 6. PC Sheets Location



Figure 7. PC Sheets Removal

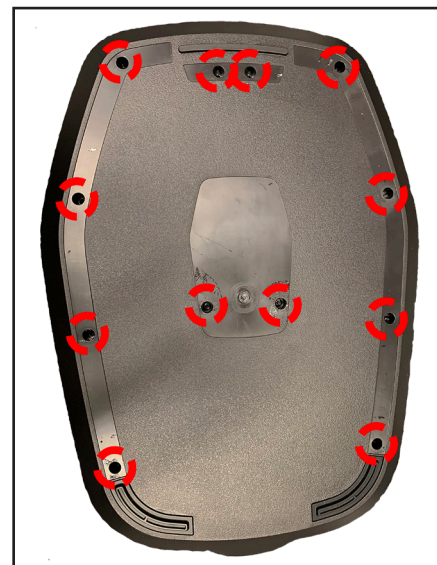

Figure 8. Enclosure Bottom Screws Removal

# DISASSEMBLY PROCEDURE

1.4 Use your hands and lift up on the Enclosure bottom as indicated in Figure 9.

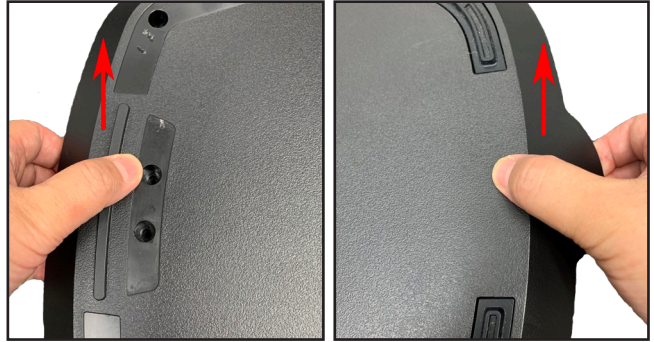

Figure 9. Enclosure Bottom Removal

## 2. Grille Removal

2.1 Perform procedure 1.

2.2 Pull the Grille out gently. Figure 10.

**Note:** When installing the Grille, make sure the Grille is inserted into the Grille guides.

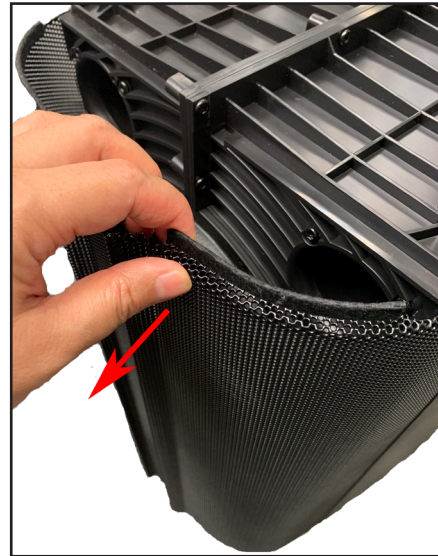

Figure 10. Grille Removal

## 3. I/O Panel Assy Removal

3.1 Remove the 12 screws securing the I/O panel assy as indicated in Figure 11.



Figure 11. I/O Panel Assy Screws Removal

# DISASSEMBLY PROCEDURE

**3.2** Incline the Power stand to let the I/O panel assy go downwards as indicated in Figure 12.

**Note:** Be careful the I/O panel assy is very heavy.

**3.3** Once the I/O panel assy is out from the Enclosure, you will notice that the 2 Volume board cables ① ② & the 1 Antenna cable ③ are attaching the Main-I/O board and the 2 Transducer harnesses ④ ⑤ are attaching the Power & Amp Board. Figure 13.

**3.4** Remove the green adhesive with IPA (Isopropyl alcohol) from the ① ② & ④ ⑤ cables' connections with Main-I/O board & Power-Amp board .

**Note:**

- Use a spudger / screwdriver to separate the green adhesive from the edge of connections.
- Be careful when regluing the green adhesive to fix the connections.

**Re-assembly Note:**

- RTV may be used if the green adhesive is not available.

**3.5** Detach all the board cables from Main I/O board & Power-Amp board except the cable ③. At this time, it can be detached only by the other end of the connection. Figure 14.

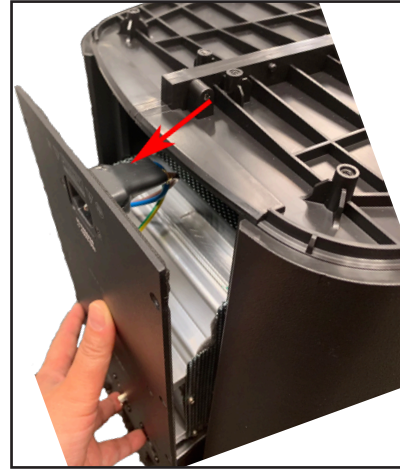

**Figure 12. Incline the Power Stand**

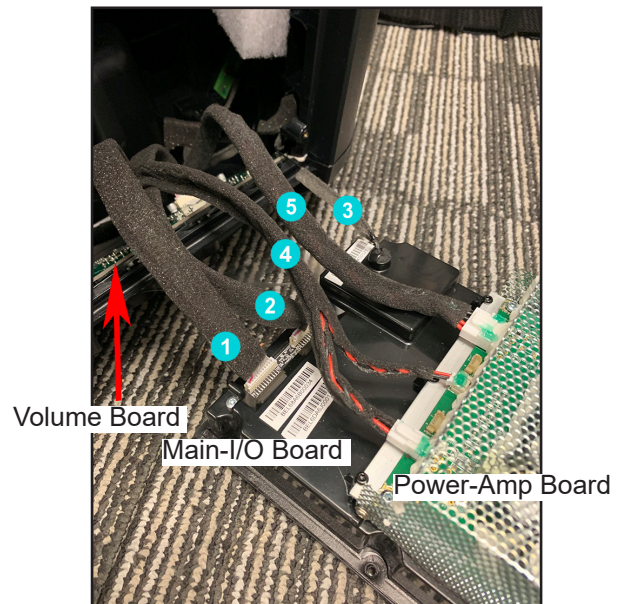

**Figure 13. Main-I/O Board & Power-Amp Board Cables**



**Figure 14. Antenna Board Screws Removal**

# DISASSEMBLY PROCEDURE

## 4. Power-Amp Board Removal

4.1 Perform procedure 3.

4.2 On the front of the I/O panel assy, remove the 6 screws (left) and turn it over to remove the 3 screws (right) securing the Power-Amp board as indicated in Figure 15.

### Re-assembly Note:

The old Heat Sink thermal grease must be removed with isopropyl alcohol and the new thermal grease, GAP FILLER, THERMAL, part number 749859-0020 MUST be used during board replacement.

Failure to use the correct thermal grease WILL cause thermal failures. Part is listed at bottom of page 14 on the Main Part List. Figure 16.

4.3 Remove the 10 screws that secure the Shield cover of Power-Amp board as indicated in Figure 17, 18.

**Note:** When installing the Shield cover, RTV need to be used to prevent buzz and vibration.

The location for RTV is same as the white glue that is originally installed.

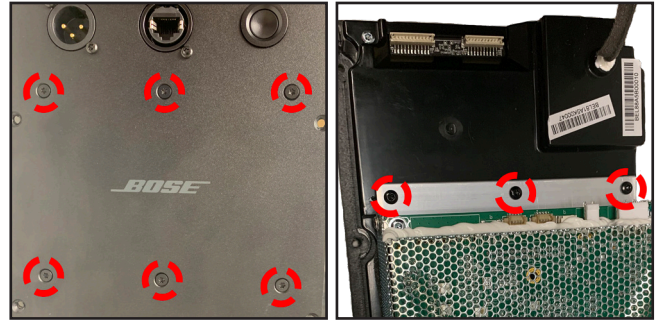

Figure 15. Power-Amp Board Screws Removal



Figure 16. Heat Sink Thermal Grease

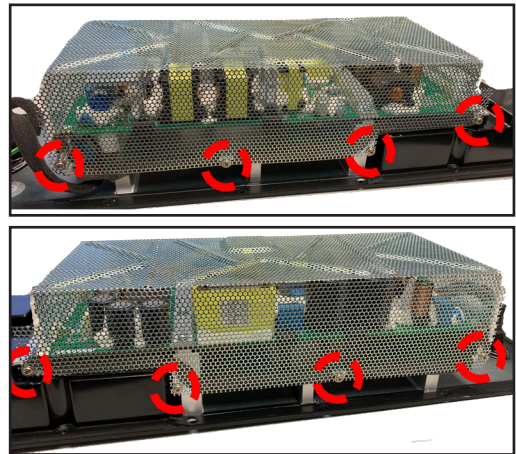

Figure 17. Shield Cover Screws Removal 1

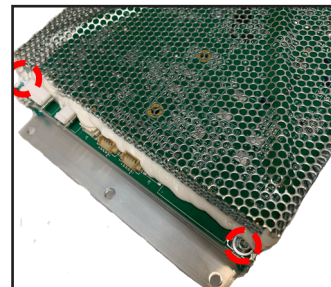

Figure 18. Shield Cover Screws Removal 2



# DISASSEMBLY PROCEDURE

**4.4** Use a spudger to separate the white glue from the edge of PCB as indicated in Figure 19.

## 5. Main-I/O Board Removal

**5.1** Perform step 4. On the Fire box, remove the 5 screws that secure the Main-I/O board as indicated in Figure 20 (left).

**5.2** Remove the RTV in the hole with tweezers as the red arrow indicated in Figure 20 (left).

**Note:** Be careful the *Bluetooth* antenna cable when removing the RTV as it is fragile.

The new RTV need to be applied to the hole when the fire box is re-installed.

**5.3** Lift the Fire box up and remove the 2 screws securing the Main I/O board. Figure 20 (right).

**5.4** Remove the green adhesive holding the *Bluetooth* antenna cable and disconnect the *Bluetooth* antenna connector as the red arrow indicated in Figure 20 (right).

**Note:** The new green adhesive need to be applied. Either hot melt or RTV is fine.

**5.5** On the front of I/O panel assy, remove the 8 screws securing the 4 Jacks. Figure 21.

**5.6** Use a nut driver or socket to turn ¼ turn to remove the 1/4' Jack socket nut out as the red arrow indicated in Figure 21.

### Re-assembly Note:

There are no Device ID concerns when replacing the main board. The Device ID is assigned at the factory. Service replacement Main PCBA's use the PCBA serial number instead of the system serial number. As a result, the system serial number will not show up in the L1 Mix app.

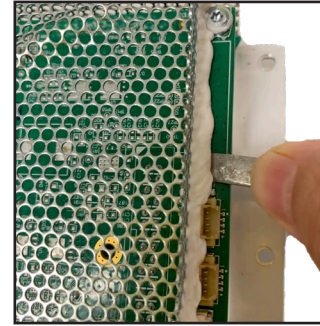

Figure 19. White Glue Removal

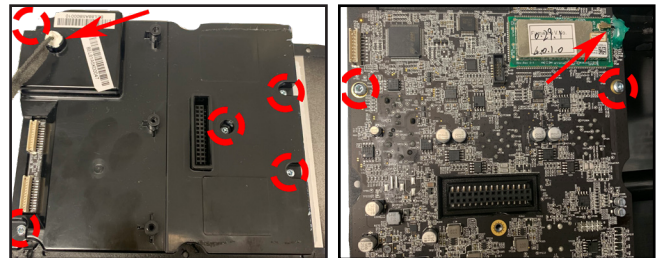

Figure 20. Fire Box & Main-I/O Board Screws Removal



Figure 21. 4 Jacks and Jack Socket Nut Removal

# DISASSEMBLY PROCEDURE

## 6. Volume Board Removal

6.1 Perform step 3.

6.2 Remove the 4 screws that secure the Volume board as indicated in Figure 22.

6.3 Pull the 3 Volume knobs out and lift off the board.

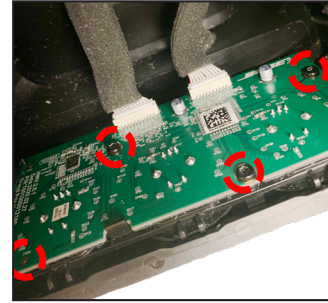

Figure 22. Volume Board Screws Removal

## 7. Woofer Removal

7.1 Perform step 2.

7.2 Remove the 12 screws securing the Woofer as indicated in Figure 23.



Figure 23. Woofer Screws Removal

7.3 Detach the 2 Cable harnesses from the Woofer by pressing the white fastener. Figure 24.

**Note:** Be careful the Woofer is very heavy.



Figure 24. Press the White Fastener

## L1 Pro16 Array Procedures

### 1. Grille Removal

1.1 Remove the 8 screws that secure the Endcaps from both ends of the Line Array as indicated in Figure 25.



Figure 25. Both Ends of Endcaps Screws Removal

# DISASSEMBLY PROCEDURE

1.2 Lift off the Top and Lower endcap. Figure 26.

**Note:** Be careful the cable of Lower endcap is very short.

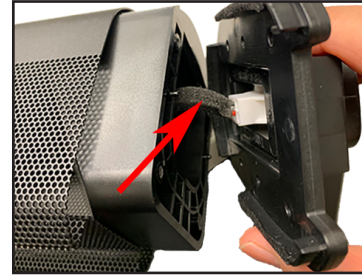

Figure 26. Lower Endcap Removal

1.3 Grasp the Grille and carefully slide the grille off of the baffle. Figure 27.

**Re-assembly Note:** Be sure there is sufficient gasket material on the Grille to prevent buzzes as the red arrow indicated in Figure 28.

Gasket material PN: 843112-0101

Perform the Array sweep tests after replacing the Grille.



Figure 27. Array Grille Removal

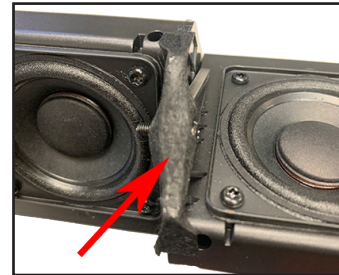

Figure 28. Gasket Material Locations

## 2. Drivers Removal

2.1 Perform procedure 1.

2.2 Remove the 4 screws securing the 1 Driver to the Baffle as indicated in Figure 29 (left).

2.3 Detach the Driver's cable by pressing the white fastener. Figure 29 (right).

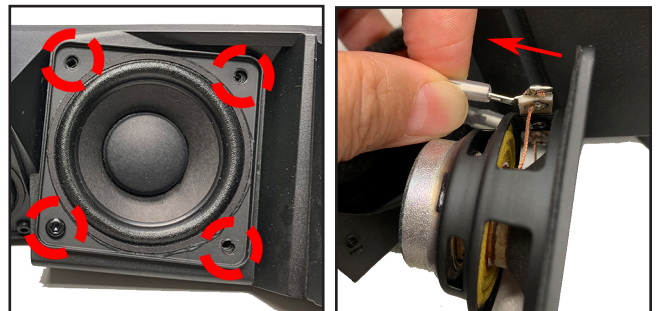

Figure 29. Driver Screws & Cable Removal

## Array Extensions

**Note:** The Array extensions are not repairable.

If damaged they must be replaced.

# TEST PROCEDURE

## Required Equipment:

1. Bose L1 Pro16 Power Stand and Line Array (unit under test)
2. Audio Signal Generator, Audio Precision ATS-1 or equivalent
3. iPod Touch/Smart Phone with audio test files / music installed
4. T4S or T8S (with power supply) and ToneMatch cable
5. Multi-meter
6. Cables listed below:
  - XLR audio cable
  - 1/8 inch audio cable
  - 1/4 inch TRS audio cable
  - AC Line cord - per region - refer to packaging part list

## Set-up & Connections:

- Connect the Power Stand AC line cord to AC Mains.
- Assemble the Line Array to the Power Stand

## Functional Tests:

### 1. Button and Knob Functionality Test

Refer to the Figure at right for this test

**1.1** Press the STANDBY button (11) on the Power Stand to turn on the power stand. Verify that the LED lights.

**1.2** Rotate the Channel 1 Channel Parameter Control knob (1). Verify that the LED's light around the control as you rotate.

**1.3** Press the Channel 1 Channel Parameter Control to step through each of the selections. Verify that the associated LED lights.

**1.4** Repeat steps 1.1 and 1.2 for the two remaining channels. Note: The Signal/Clip LED's (2) will be tested during the signal input tests later in this procedure.

**1.5** Press the Channel 1 CHANNEL MUTE button (3). Verify that it lights. Press again to turn off the Mute function. LED should go out. Repeat for channels 2 and 3.

**1.6** Press the Channel 1 ToneMatch button (4). Verify that one of the three selections is lit. Press the button twice more to verify that all 3 selections will light sequentially. Repeat for channel 2.

**1.7** Press the PHANTOM POWER button (6). It should light. Press the button again to turn off Phantom power.

**1.8** Press the SYSTEM EQ button to scroll through the EQ selections. The corresponding LED will illuminate white while selected.

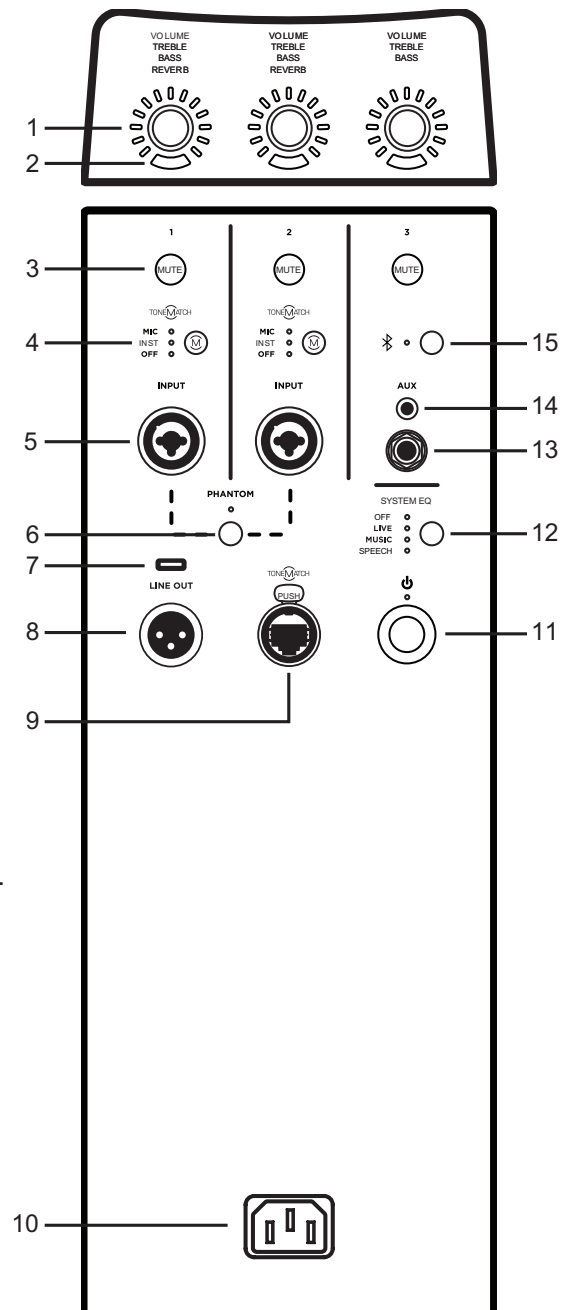

# TEST PROCEDURE

## 2. Line Input / Output Verification Tests

Refer to the Connections and Controls diagram on the previous page for the following tests.

**Note:** DO NOT assemble the line array to the power stand. The below test would be very loud with the array connected to the power stand.

**2.1** Connect the AC power cord to the power stand and to AC Mains. Press the STANDBY button (11) to turn on the power stand. The button should illuminate white.

**2.2** Set the channel 1 volume control (1) to 50%. Set the Channel ToneMatch button (4) and the Mute button (3) to OFF.

**2.3** Apply a balanced, 150mV, 1 kHz audio signal to the Channel 1 XLR audio input (5).

**2.4** Measure the output level at the Line Out jack (8). This is a balanced output. Output level should be 11.0 dBV  $\pm$  2 dB, THD <1%.

**2.5** Change the input frequency to 20 Hz. Measure the output level at the Line Out jack (8). Output level should be 11.0 dBV  $\pm$  3 dB, THD <1%.

**2.6** Change the input frequency to 20 kHz. Measure the output level at the Line Out jack (8). Output level should be 11.0 dBV  $\pm$  3 dB, THD <1%.

**2.7** Repeat steps 2.2 to 2.6 for the Channel 1 TRS input. Output levels should be -3.2 dBV  $\pm$  2 dB at 1 kHz input,  $\pm$  3 dB at 20 Hz and 20 kHz inputs.

**2.8** Repeat steps 2.2 to 2.7 for the Channel 2 XLR and TRS inputs.

**2.9** Apply a balanced, 150mV, 1 kHz audio signal to the Channel 3 Aux 1/4" input.

**Note:** The Channel 3 Aux 1/4" input is a mono balanced TRS input.

**2.10** Measure the output level at the Line Out jack (8). Output levels should be -16.5 dBV  $\pm$  2 dB at 1 kHz input,  $\pm$  3 dB at 20 Hz and 20 kHz inputs.

**2.11** Apply 150mV, 1 kHz stereo (left/right) audio signal to the Channel 3 Aux 1/8" input.

**Note:** The Channel 3 Aux input is a stereo unbalanced TRS input.

**2.12** Measure the output level at the Line Out jack (8). Output levels should be -4.0 dBV  $\pm$  2 dB at 1 kHz input,  $\pm$  3 dB at 20 Hz and 20 kHz inputs.

## 3. System Sweep Test

**3.1** Assemble the line array to the power stand. Connect the AC power cord to the power stand and to AC Mains. Press the STANDBY button (11) to turn on the power stand. The button should illuminate white.

**3.2** Set the Channel 1 volume control (1) fully CCW. Set the TREBLE and BASS settings to mid and the REVERB to minimum. Set the Channel 1 ToneMatch button (4) and the Mute button (3) to OFF.

# TEST PROCEDURE

**3.3** Apply a 250mV, 1kHz balanced audio signal into the channel 1, 1/4" TRS audio input (5).

**CAUTION:** This test will be very loud. Hearing Protection is required.

**3.4** Set the Channel 1 volume control to 8. Verify that the SIGNAL/CLIP indicator (2) is lit green. Sweep the input frequency 40Hz to 2kHz over a period of six seconds. Listen from a distance of 12 - 20 inches (30 - 50cm). Verify that you hear no buzzing, air leaks or other artifacts. Repeat sweep 3 times.

**3.5** Set the input frequency to 1kHz. Rotate the Channel 1 Parameter control (1) to change the volume level between 0 and 8. Verify that the sound output level changes and that there is no noticeable distortion or other audio artifacts.

**3.6** Set the volume control to 8. Slowly increase the input signal level from the Audio Signal Generator. Verify that the Signal/Clip indicator changes from Green to Red. Reduce the input level back to 250mV.

**3.7** Apply a 250mV, balanced mono music signal to the channel 1 1/4" TRS jack. Press the Channel 1 Parameter control to change function to Treble. Rotate the control to change the treble level. Verify that the treble changes. Press the control to change to Bass. Verify that the bass level changes. Press the control to change to Reverb. Verify that the reverb level changes when you rotate the control.

**3.8** Repeat steps 3.2 to 3.6 for the Channel 2 TRS input and Channel 3 Aux 1/4" and 1/8" inputs. Ensure that the Channel 3 SYSTEM EQ is set to MUSIC. **Note:** The Channel 3 Aux 1/4" jack is a mono balanced TRS input and the Channel 3 Aux 1/8" jack is a stereo unbalanced TRS input.

## 4. Bluetooth Connection and L1 Mix App Test

**4.1** Press and hold the BLUETOOTH PAIR button (15) for 2 seconds. It is located above the Channel 3 AUX input. It will flash BLUE while the L1 Pro power stand is discoverable.

**4.2** Using a Smart phone or similar, open your Bluetooth connections settings. Look for the L1 Pro8 and connect to it. Once you are connected the BLUETOOTH PAIR button on the power stand will illuminate solid white. While connected, stream music audio and verify that you have clean audio playback.

**4.3** Download and install the L1 Mix app on the Smart phone or other device. It is available at the Apple App Store and Google Play. Open the app and verify that you can connect to the product and control it using the app. Note: The L1 Mix app operates via Bluetooth. Go to [pro.bose.com](http://pro.bose.com) for more app information.

## 5. ToneMatch Input Test

**5.1** Using a ToneMatch cable, connect a T4S or T8S to the ToneMatch input (9).

**CAUTION:** Do not connect to a computer, computer network or phone network. Damage to the product could result.

### Important Note:

1. The T1 ToneMatch is not compatible for this test. The power stand can supply power to the T1, but cannot receive audio from the T1 via the ToneMatch connection. Audio from a T1 must be input through one of the audio input connections on the power stand.

# TEST PROCEDURE

**5.2** Connect an audio input to the T4S/T8S. Verify that you can play the audio from the T4S/T8S through the power stand with no noticeable distortion.

## 6. Phantom Power Test

**6.1** Press the STANDBY button (11) to turn on the power stand. The button should illuminate white.

**6.2** Press the Phantom Power button (6) on the power stand. It should illuminate white.

**Note:** You can use a condenser microphone for this test. Connect to the Channel 1 input XLR Combo jack. Speak into the microphone and verify that you can pass audio. Repeat for Channel 2.

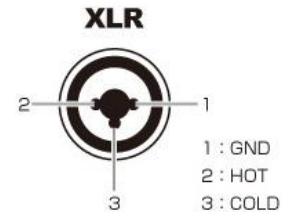

**6.3** Using a multi-meter, carefully measure the DC voltage across pins 1 and 2 of the Channel 1 input XLR Combo connector. It should read +48Vdc +/- 5Vdc. Measure the DC voltage across pins 1 and 3 of the same connector. It should read +48Vdc +/- 5Vdc. Repeat step for the Channel 2 input XLR connector.

**CAUTION:** Take care to not short across the pins or you will damage the unit.







## 7. Button Extended Functions Test

**7.1** Perform the button tests below to verify extended functionality of the buttons/controls.

Product I/O	User control	Trigger	User action
	Power button	Short press the power button when system is off/on	Power LED on and system power on/off
		Press and hold the button for 10 sec	All LEDs light then all the settings will be set to default and reboot the system
	BT button	Press and hold the BT button for 2 seconds	BT LED will blink in 2Hz (0.5 sec on and 0.5 sec off). Start the BT pairing/Disconnect any BT connection.
		Short press x1	If BT is not connected and pairing list is not empty, start BT reconnect. If BT pairing in progress, stop BT pairing mode.
		Press and Hold 10 seconds	Bluetooth factory reset and clear all current devices.
	ToneMatch button	Short press the Tone-Match button and the LED to position-1/2	Microphone/guitar LED will be ON. Enable EQ for Microphone/Acoustic guitar
		Short press the Tone-Match button and the LED to position-3	Indication Microphone LED will be ON. Disable EQ
		Press and Hold 10 seconds	Factory reset of ToneMatch settings

# TEST PROCEDURE

## Button Extended Functions Test (continued):

Product I/O	User control	Trigger	User action
	House Curve button	Short press the button and the LED to position-1/2/3/4	“Off/Live/Music/Speech” LED will be ON. Select corresponding House Curve. Flat/Live/DJ/Voice LED
	Encoder button	Short press the encoder	Channel LED: To position-1 is volume, position-2 is Treble, position-3 is Bass, position-4 is Reverb. Ring LEDs will update according to the parameters level.
		Rotate knob clockwise/counter-clockwise	Ring LEDs will be updated and Audio specific channel parameter level will be adjusted.
		Press and hold 3 parameter rotary encoder buttons 10 seconds	Disable/Enable Low Power standby mode. Power LED will blink 3 times for enable and 6 times for disable.
		Press and hold the rotary encoder button for 3 seconds when channel is in the reverb	Disable/Enable reverb mute. Reverb channel LED will blink at 1Hz for enable and solid white for Disable
	Channel Mute button	Short press the button to mute channel audio	Mute/Unmute Channel. Channel mute LED will be on when Mute and off when unmute
	Phantom	1st short press the button	LED to position 1 ON. Activates phantom power on channels 1 & 2 for a condenser microphone
		2nd short press the button	LED to position 2 OFF. De-activates phantom power on channels 1 & 2 for a condenser microphone

7.2 Before returning the system to the customer, Factory Default the system by pressing and holding the Power Button for 10 seconds.



# HI-POT TEST

## 1. Hi-Pot Test

### **THIS IS A MANDATORY TEST**

**CAUTION** - All units that are disassembled as part of a repair **MUST** be Hi-Pot tested before being returned to the customer.

This test applies a high voltage to the AC line cord and measures the current leakage to the chassis and/or other metal parts on the outside of the unit to check for potential shock hazards.

If the unit fails Hi-Pot test, it must be returned to the technician for troubleshooting and repair of the problem, after which it must be Hi-Pot tested again.

### **Hi-Pot Tester Settings:**

Type of product: 100-240 VAC 2-wire Class II  
Test Voltage: 1591 VAC  
Trip Current Limits: 0.5mA min, 10mA max  
Ramp: 1 second  
Dwell: 4 seconds

## Procedure

**1.1** Connect the positive side (hot) of the Hi-Pot tester to both terminals of the AC mains input.

**1.2** Connect the return of the Hi-Pot tester to the channel 1 to 3 audio connector ground connections. Pin 1 on the channel 1 and 2 XLR combo jacks, sleeve of 1/8" and 1/4" inputs and the shell of the Service USB-C jack.

This test must be performed only after the system has been completely assembled. Failure of this test indicates a faulty transformer, defective or incorrectly dressed primary wiring, improperly attached leads, surface contamination of either the power supply board or the I/O connector board, or incorrectly adjusted trip point on tester.

# SOFTWARE UPDATE

These instructions explain how to update the firmware of your L1 Pro8, L1 Pro16, L1 Pro32, Sub1, or Sub2.

**Note:** A USB-C cable is required (not included with your product). The L1 Pro family of products is not compatible with Thunderbolt 3 cables.

1. On a computer, open a web browser and go to **btu.bose.com**.  
**Note:** Not compatible with Internet Explorer or Safari.
2. Click **Download** to download the **Bose Updater**.

Compatible Web Browsers	
Windows	Google Chrome, Mozilla Firefox, Microsoft Edge
Mac	Google Chrome, Mozilla Firefox

## Bose Updater

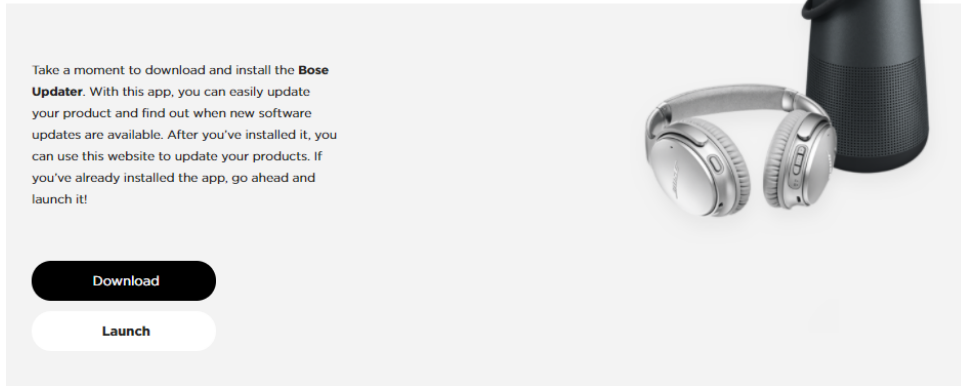

3. View the End-User License Agreement, then click **I Agree**.
4. Install the **Updater**.

## Bose Updater

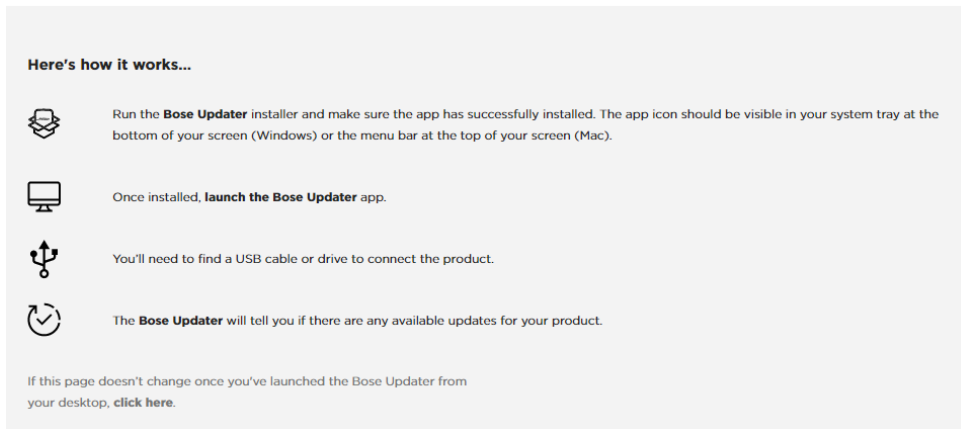

5. Once installed, open the **Updater**.
6. Plug your product into a power source.
7. Connect your product to your computer using a USB-C cable. The **Updater** will identify your product automatically.

# SOFTWARE UPDATE

8. If your product needs a software update, your screen will read, **There's an update available for your product!**

## Bose Updater

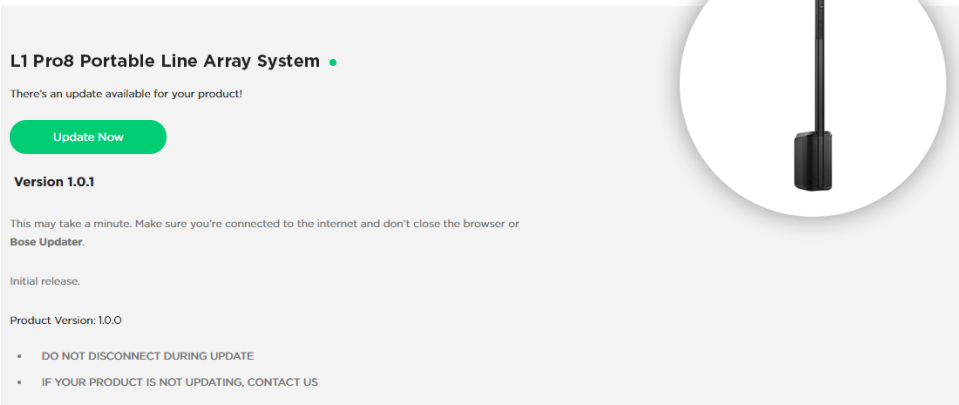

**L1 Pro8 Portable Line Array System** •

There's an update available for your product!

**Update Now**

**Version 1.0.1**

This may take a minute. Make sure you're connected to the internet and don't close the browser or **Bose Updater**.

Initial release.

Product Version: 1.0.0

- DO NOT DISCONNECT DURING UPDATE
- IF YOUR PRODUCT IS NOT UPDATING, CONTACT US

9. Click **Update Now**.  
**Note:** Do not unplug or power off your product while the update is in progress.

## Bose Updater

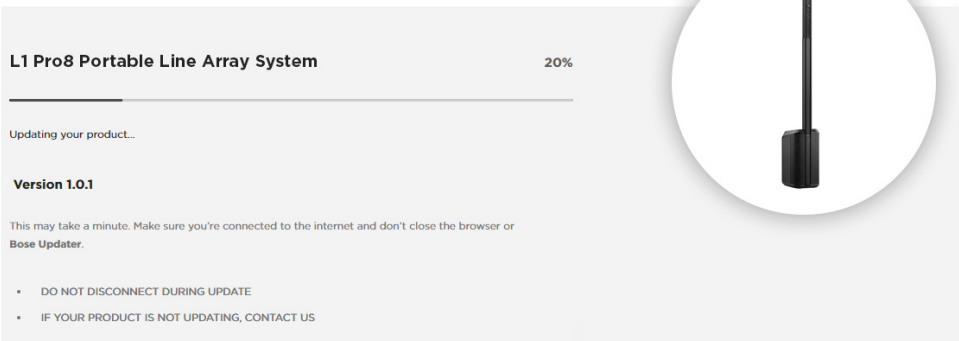

**L1 Pro8 Portable Line Array System** 20%

Updating your product...

**Version 1.0.1**

This may take a minute. Make sure you're connected to the internet and don't close the browser or **Bose Updater**.

- DO NOT DISCONNECT DURING UPDATE
- IF YOUR PRODUCT IS NOT UPDATING, CONTACT US

10. Once the update is complete, your screen will read, **Your product is now up-to-date!**

## Bose Updater

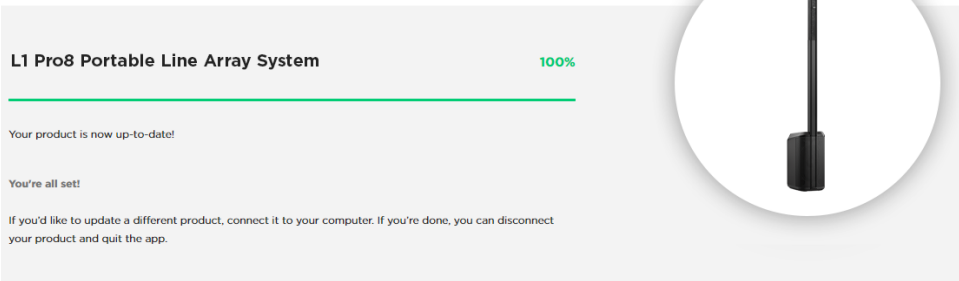

**L1 Pro8 Portable Line Array System** 100%

Your product is now up-to-date!

You're all set!

If you'd like to update a different product, connect it to your computer. If you're done, you can disconnect your product and quit the app.

# SERVICE MANUAL REVISION HISTORY

<b>Date</b>	<b>Revision Level</b>	<b>Description of Changes</b>	<b>Changes Driven By</b>	<b>Pages (s) Affected</b>
12/7/2020	00	Document released at revision 00	Initial Release	ALL
12/24/2020	01	Add Software Update		P 50, 51
2/17/2022	02	Add Item 4 - Item 10		P 9

---

***BOSE***®  
***Better sound through research***®

Bose Corporation  
100 The Mountain Road  
Framingham Massachusetts USA 01701

Reference Number 840920-SM REV 01, 2/2022  
<http://serviceops.bose.com>